



Superior Clamping and Gripping



Product Information

Rotary gripping module with parallel gripper EGS 25

EGS

Rotary gripping module with parallel gripper

Easy. Fast. Compact. Gripper swivel Module EGS

Electric, 2-finger, parallel gripper swivel module with smoothly running base jaws guidance on roller bearings

Field of application

Gripping and moving of small to medium-sized workpieces with flexible force and high speed in clean environments, such as assembly, testing, laboratory and pharmaceutical industry

Advantages – Your benefits

Control via digital I/O for easy commissioning and rapid integration into existing systems.

Almost no wear parts for high machine uptime and low operating costs

Small required space as the rotary drive and gripper are merged in one compact module

Two to four stage adjustable gripping force for simple adaption to sensitive workpieces

Four stage adjustable rotational speed for high flexibility in cycle times

Very high maximum cycles per minute for highest productivity

Backlash-free, pre-loaded cross roller guide for precise gripping with nearly constant force for all permissible finger lengths

Standardized mounting bores for numerous combinations with other components from the modular system



Sizes
Quantity: 2

m

Weight
0.45 .. 1.2 kg



Gripping force
30 .. 140 N



Stroke per jaw
3 .. 6 mm



Torque
0.04 .. 0.115 Nm

Functional description

The gripper swivel module has two stationary brushless servomotor drives. The outer motor rotates the gripper. The inner motor drives the base jaw of the gripper. The jaw stroke is synchronized by a rack and pinion kinematic.



- | | |
|---|--|
| <p>① Base Jaw
for the connection of workpiece-specific gripper fingers</p> <p>② Cross roller guidance
precise gripping due to backlash-free base jaw guidance</p> <p>③ Sensor system
Inductive monitoring of swiveling and gripping movement</p> | <p>④ Drives
Brushless DC servomotors</p> <p>⑤ Control electronics
integrated control and power electronics for decentralized actuation of the servomotors</p> <p>⑥ Patented gear coupling
Endless rotation without an electric feed-through</p> |
|---|--|

General notes about the series

Operating principle: Rack and pinion principle

Housing material: Aluminum alloy, coated

Base jaw material: Steel

Actuation: servo-electric, via brushless DC servomotors

Warranty: 24 months

Scope of delivery: Enclosed pack with centering sleeves, mount for proximity switch, assembly and operating manual with Declaration of Incorporation.

Gripping force: is the arithmetic sum of the individual force applied to each jaw at distance P (see illustration).

Finger length: is measured from the reference surface as the distance P in direction to the main axis.

Repeat accuracy: is defined as a distribution of the end Position for 100 consecutive strokes.

Workpiece weight: is calculated for force-fit gripping with a coefficient of static friction of 0.1 and a safety factor of 2 against workpiece slippage at acceleration due to gravity g. For form-fit or capture gripping, there are significantly higher permissible workpiece weights.

Closing, opening and swiveling times: are pure movement times of the module. PLC reaction times are not included and have to be considered when the cycle times are determined.

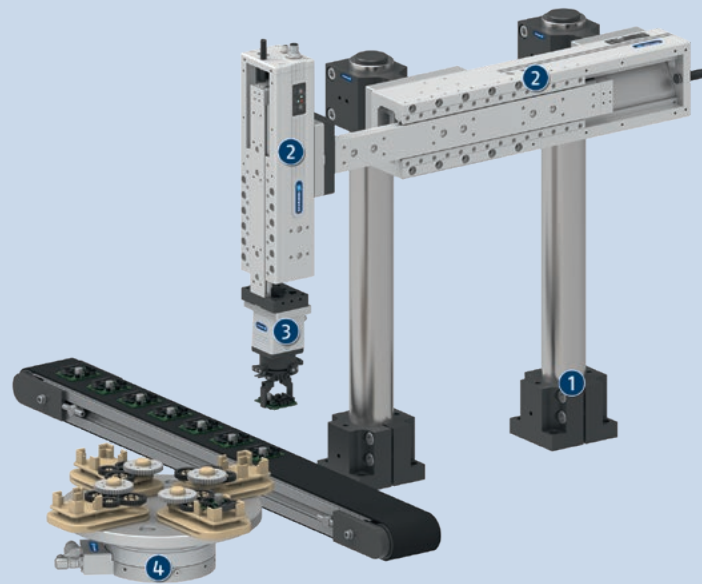

Application example

Electrically driven pick & place unit with gripper swivel module for simultaneous turning and shifting of electronic components.

- 1 Pillar assembly system
- 2 Electric linear module ELP

- 3 Electric gripper swivel module EGS
- 4 Universal rotary module ERS

SCHUNK offers more ...

The following components make the product even more productive – the suitable addition for the highest functionality, flexibility, reliability, and controlled production.



Linear module



Pick & Place Unit



Gripper for small components



Pillar assembly system



Connection cables



Inductive proximity switches



Finger blank

① For more information on these products can be found on the following product pages or at schunk.com.

Options and special information

Manually adjustable gripping force: With an integrated rotary switch, the gripping force can be adjusted in two stages for the EGS 25 – 100% and 50%, and in four stages for EGS 40 – 100%, 75%, 50%, and 25%.

Manually adjustable rotational speed: With an integrated rotary switch, the rotational speed can be adjusted in four stages – 100%, 75%, 50%, and 25%.

Optional status monitoring via external sensor system: The status of the gripping and swiveling movements can be monitored by external sensors.

KA connection cable: Connection cables with an angled or a straight female connector can be ordered in various lengths to connect the module with the power supply and higher-level control system.

EGS 25

Rotary gripping module with parallel gripper



Gripping force

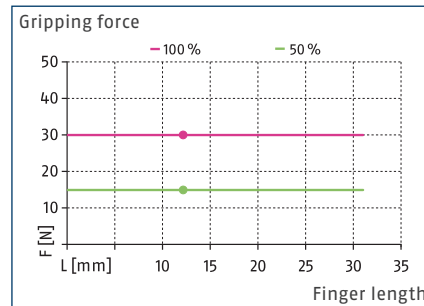

Swiveling time* 180°

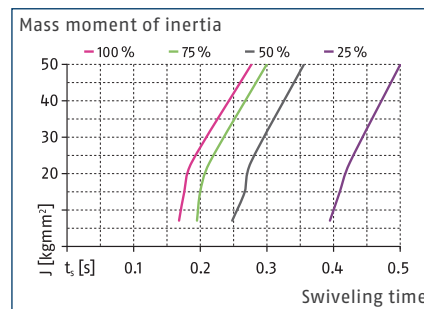

Dimensions and maximum loads

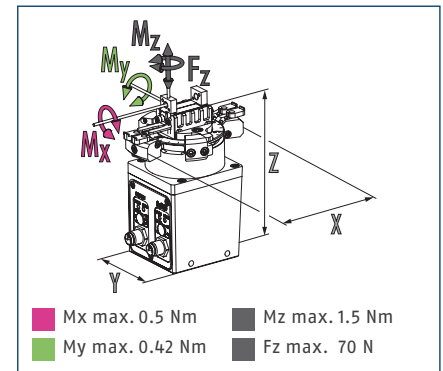

① The indicated moments and forces are static values, apply for each base jaw and may appear simultaneously. Loads may additionally occur to the moment produced by the gripping force itself.

Technical data

Description		EGS 25-N-N-B
ID		0310820
General operating data		
Stroke per jaw	[mm]	3
Min./max. gripping force	[N]	15/30
Nominal torque	[Nm]	0.04
Min./max. angle of rotation	[°]	30/270
Recommended workpiece weight	[kg]	0.15
Max. permissible finger length	[mm]	32
Max. permissible mass per finger	[kg]	0.02
Max. mass moment of inertia	[kgmm ²]	50
Repeat accuracy for gripping	[mm]	0.02
Repeat accuracy for swiveling	[°]	±0.5
Closing/opening time	[s]	0.05/0.05
Weight	[kg]	0.45
Min./max. ambient temperature	[°C]	5/55
IP protection class		30
Noise emission	[dB(A)]	<70
Dimensions X x Y x Z	[mm]	69.8 x 45 x 88.8
Electrical operating data		
Controller electronics		integrated
Nominal voltage	[V]	24
Nominal current	[A]	0.8
Max. current	[A]	1.2
Communication interface		Digital inputs

* The diagram is valid for applications with vertical rotary axis or for absolutely centric loads with horizontal rotary axis. We will gladly support you in designing further applications.

Main view

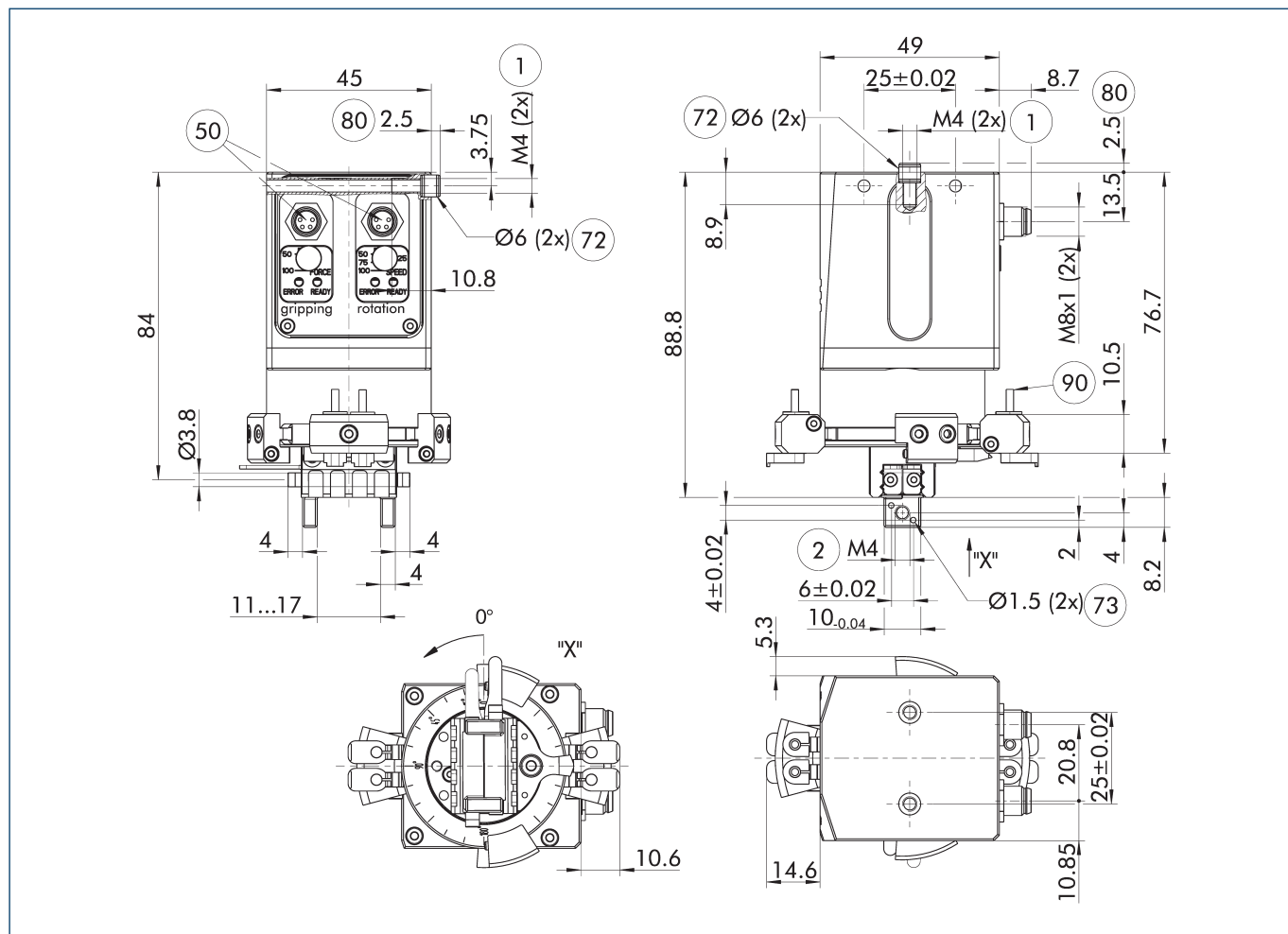

The drawing shows the basic version of the gripper with open jaws, without dimensional consideration of the options described below.

- ① Connection gripper swivel module
- ② Finger connection
- ⑤ Electrical connection
- ⑦ Fit for centering sleeves
- ⑦③ Fit for centering pins
- ⑧⑩ Depth of the centering sleeve hole in the counter part
- ⑨⑩ Sensor IN ...

Maximum permitted finger projection

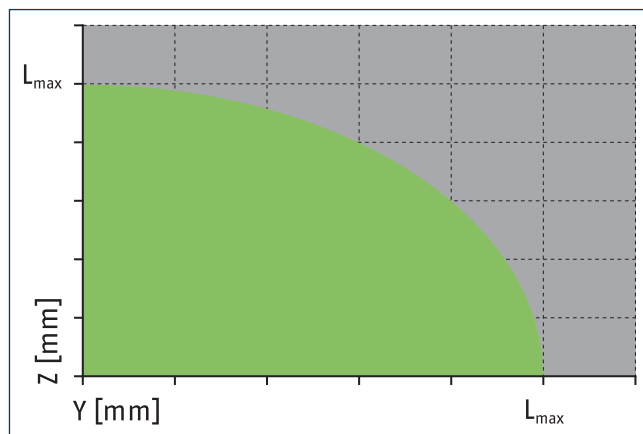
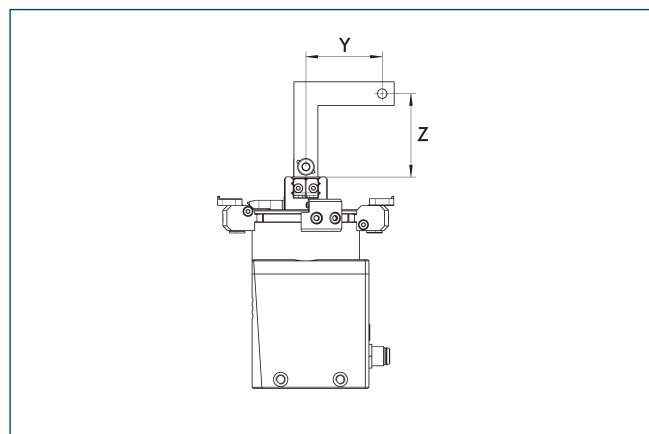

■ Permitted range ■ Inadmissible range

L_{max} is equivalent to the maximum permitted finger length, see the technical data table.

EGS 25

Rotary gripping module with parallel gripper

Jaw design

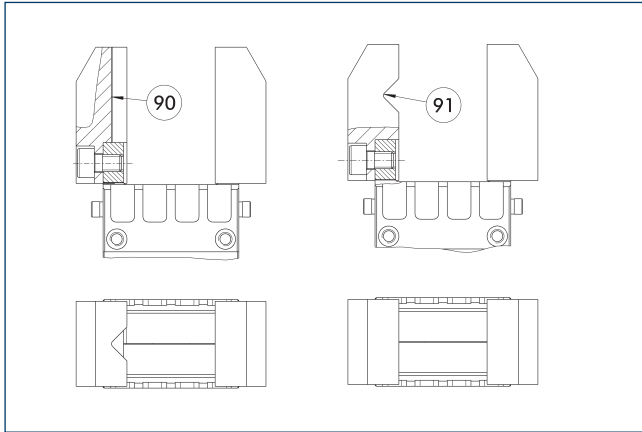

90 Vertically positioned prism 91 Horizontally positioned prism

A workpiece, which is gripped using three points of contact, can be reliably gripped with high repeatability. A system with more than three points of contact is overdetermined. The drawing shows two alternative gripper finger designs for coaxial and radial gripping of a cylindrical part.

Finger blanks with BSWS ABR-BSWS-MPG-plus 25

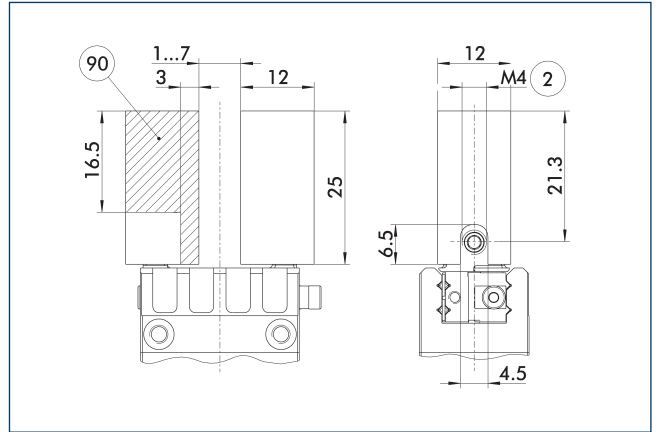

2 Finger connection 90 Machining volume

Finger blanks for customized subsequent machining with integrated jaw quick-change system for precise and fast finger changes.

Description	ID	Scope of delivery
Finger blank with jaw quick-change system		
ABR-BSWS-MPG-plus 25	0302894	2

Finger blanks with BSWS

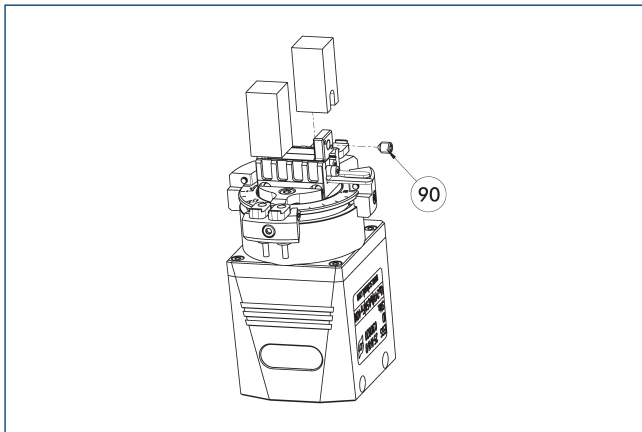

90 Included in the scope of delivery

The finger blanks with jaw quick-change system allow fast and manual gripper finger changes. The mechanical interface to the gripper is already integrated. Only the specific workpiece geometry needs to be machined into the finger blank.

Description	ID	Scope of delivery
Finger blank with jaw quick-change system		
ABR-BSWS-MPG-plus 25	0302894	2

Finger blanks ABR-MPG-plus 25

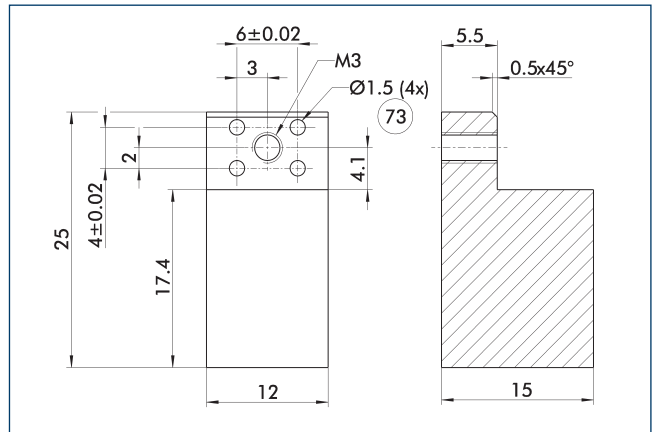

73 Fit for centering pins

The drawing shows the finger blank which can be reworked by the customer.

Description	ID	Material	Scope of delivery
Finger blank			
ABR-MPG-plus 25	0340211	Aluminum	2

Modular Assembly Automation

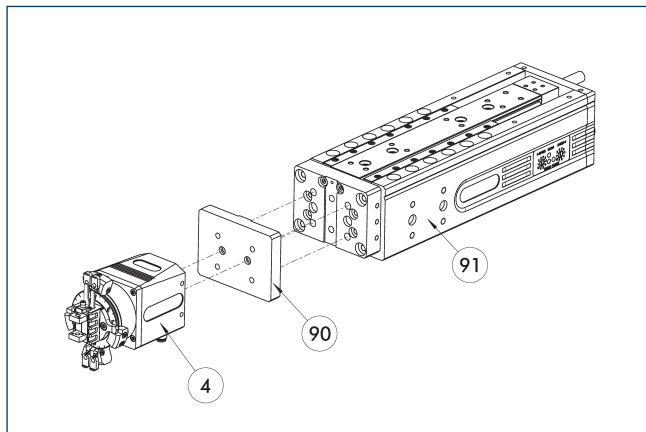

- ④ Rotary gripper module ⑨① CLM/KLM/LM/ELP/ELM/ELS/HLM
 ⑨② ASG adapter plate linear modules

Grippers and linear modules can be combined with standard adapter plates from the modular assembly system. For more information see our main catalog "Modular Assembly Automation".

Inductive Proximity Switches

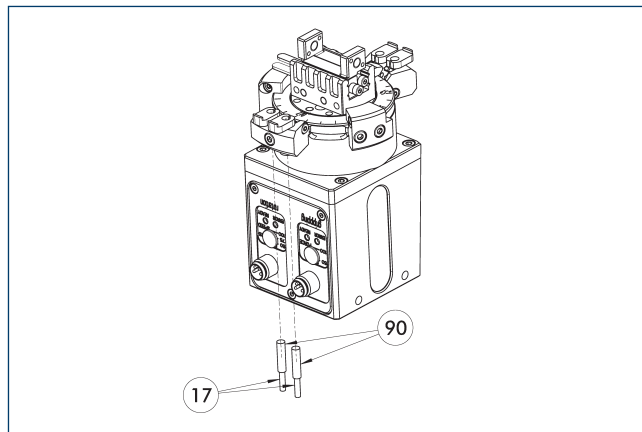

- ①⑦ Cable outlet ⑨② Sensor IN ...

Description	ID	Often combined
Inductive proximity switches		
IN 30K-S-M8-PNP	1001272	
Connection cables		
KA BG08-L 3P-0300-PNP	0301622	●
KA BG08-L 3P-0500-PNP	0301623	
KA BW08-L 3P-0300-PNP	0301594	
KA BW08-L 3P-0500-PNP	0301502	
clip for plug/socket		
CLI-M8	0301463	
Cable extension		
KV BW08-SG08 3P-0030-PNP	0301495	
KV BW08-SG08 3P-0100-PNP	0301496	
KV BW08-SG08 3P-0200-PNP	0301497	●
Sensor distributor		
V2-M8	0301775	●
V4-M8	0301746	
V8-M8	0301751	

- ① Four sensors (closer/S) are required for each unit and extension cables are available as an option. For sensor cables, note the minimum permissible bending radii. These are generally 35 mm.

Connection cables

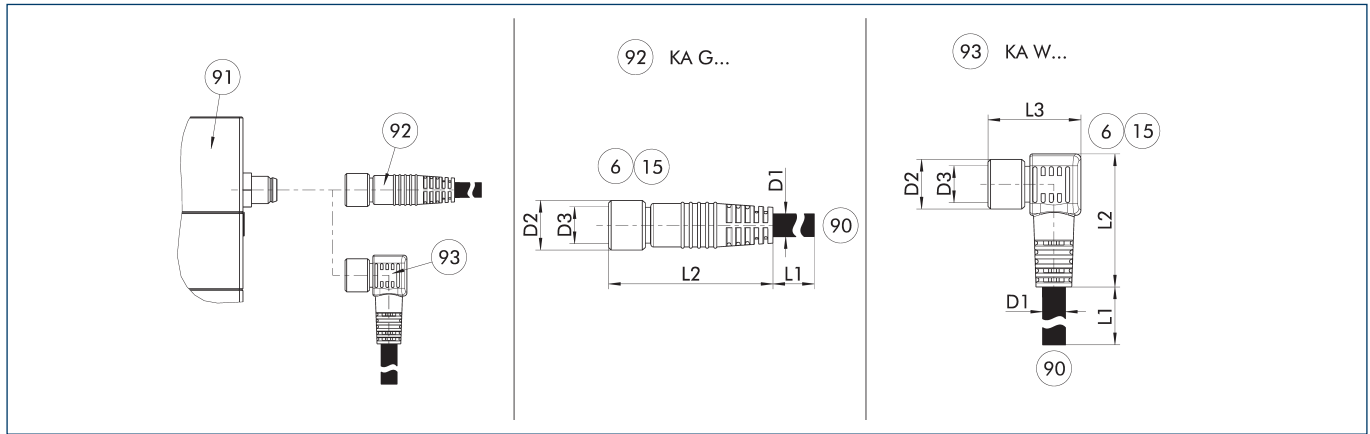

KA G... Connection cable with straight socket
 KA W... Connection cable with angular socket

- ⑥ Connection module side
- ⑬ Socket
- ⑨⑩ SAC connection cable with open wire strands
- ⑨① Connection plug component
- ⑨② Cable with straight female connector
- ⑨③ Cable with angled female connector

The connection cable is ideal for connecting the corresponding components to the controller or the power supply unit. The connection cable has a 4-pin M8 socket on one side and an open wire strand on the other side for individual connections. The connection cables are suitable for use both in the cable track as well as in torsion applications.

Description	ID	L1 [m]	D1 [mm]	L2 [mm]	D2 [mm]	L3 [mm]	D3	Often combined
Connection cable – suitable for drag chains and a high torsion resistance								
KA GLN0804-IO-00200-A	1310371	2	4.8	33.7	10		M8	
KA GLN0804-IO-00500-A	1310375	5	4.8	33.7	10		M8	●
KA GLN0804-IO-01000-A	1310379	10	4.8	33.7	10		M8	
KA WLN0804-IO-00200-A	1310372	2	4.8	27.9	10	18.9	M8	
KA WLN0804-IO-00500-A	1310376	5	4.8	27.9	10	18.9	M8	
KA WLN0804-IO-01000-A	1310381	10	4.8	27.9	10	18.9	M8	

① Please observe the min. bending radius for cable track-compatible cables or the max. torsion angle for torsion-compatible cables. These are generally 10 times the cable diameter or +/- 180°/m.



SCHUNK GmbH & Co. KG
Spann- und Greiftechnik

Bahnhofstr. 106 - 134
D-74348 Lauffen/Neckar
Tel. +49-7133-103-0
Fax +49-7133-103-2399
info@de.schunk.com
schunk.com

Folgen Sie uns | *Follow us*

