

# ACCESSORIES

## WCMX / SPMX

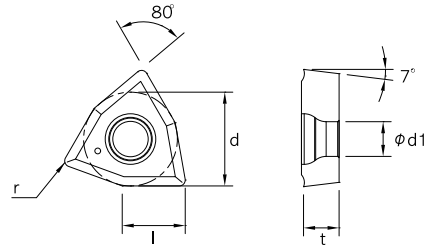

### ▶ WCMX

Code No.	치수 Dimension(mm)					부품 Parts	
	l	d	t	r	ϕd1	Screw	Driver
WCMX030204 PA	3.8	5.56	2.38	0.4	2.5	TSB-22045	TXL-6
WCMX040204 PA	4.3	6.35	2.38	0.4	2.8	TSB-25055	TXL-8
WCMX050308 PA	5.4	7.94	3.18	0.8	3.4	TSB-30070	
WCMX06T308 PA	6.5	9.525	3.97	0.8	4.4	TSB-35090	TXL-15
WCMX080408 PA	8.7	12.7	4.76	0.8	5.5	TSB-40110	

Code No.	피삭재 Workpiece					적용 드릴 For Drill			
	P	M	K	N	S	HSD(MCD)	VLT(TMD)	VMD	TPD
WCMX030204 PA	◎	○	○	△	△	ϕ16.0 ~ ϕ20.0	ϕ25	ϕ45 ~ ϕ55	-
WCMX040204 PA	◎	○	○	△	△	ϕ20.5 ~ ϕ25.0	ϕ26.0 ~ ϕ30.0	ϕ55 ~ ϕ60	-
WCMX050308 PA	◎	○	○	△	△	ϕ25.5 ~ ϕ30.0 -	ϕ31.0 ~ ϕ40.0 ϕ60.0 ~ ϕ75.0	ϕ60 ~ ϕ75 ϕ100 ~ ϕ105	ϕ40 ~ ϕ55
WCMX06T308 PA	◎	○	○	△	△	ϕ31.0 ~ ϕ41.0 ϕ59.0 ~ ϕ80.0	ϕ41.0 ~ ϕ50.0 ϕ75.0 ~ ϕ80.0	ϕ75 ~ ϕ100 ϕ105 ~ ϕ140	ϕ60 ~ ϕ110
WCMX080408 PA	◎	○	○	△	△	ϕ42.0 ~ ϕ58.0	ϕ51.0 ~ ϕ59.0	ϕ140 ~ ϕ180	-

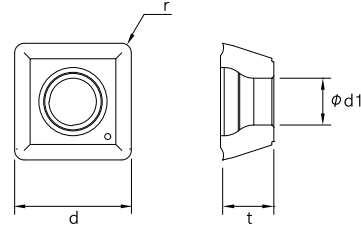
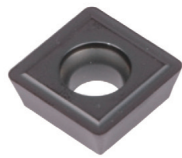

### ▶ SPMX

Code No.	치수 Dimension(mm)				부품 Parts	
	d	t	r	ϕd1	Screw	Driver
SPMX050204 PA	5.00	2.38	0.4	2.25	TSB-20045	TXL-6
SPMX060204 PA	6.00	2.38	0.4	2.61	TSB-22052	
SPMX07T308 PA	7.94	3.97	0.8	2.85	TSB-25065	TXL-8
SPMX090408 PA	9.80	4.30	0.8	4.05	TSB-35090	TXL-15
SPMX110408 PA	11.50	4.80	0.8	4.45	TSB-40100	
SPMX140512 PA	14.30	5.20	1.2	5.75	TSB-50125	TXL-20

Code No.	피삭재 Workpiece					적용 드릴 For Drill	
	P	M	K	N	S	STD-V	FXD
SPMX050204 PA	◎	○	○	△	△	ϕ13.0 ~ ϕ15.0	ϕ18.0 ~ ϕ19.5
SPMX060204 PA	◎	○	○	△	△	ϕ15.5 ~ ϕ21.5	ϕ20.0 ~ ϕ25.0
SPMX07T308 PA	◎	○	○	△	△	ϕ22.0 ~ ϕ27.5	ϕ25.5 ~ ϕ30.0
SPMX090408 PA	◎	○	○	△	△	ϕ28.0 ~ ϕ33.0 ϕ50.0 ~ ϕ60.0	- -
SPMX110408 PA	◎	○	○	△	△	ϕ34.0 ~ ϕ41.0 ϕ60.0 ~ ϕ75.0	- -
SPMX140512 PA	◎	○	○	△	△	ϕ42.0 ~ ϕ50.0 ϕ75.0 ~ ϕ80.0	- -



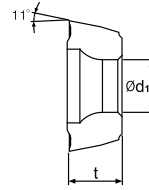
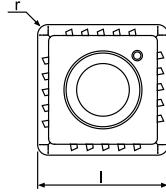

### ▶ SPMT

Code No.	치수 Dimension(mm)				부품 Parts	
	l	t	r	ød1	Screw	Driver
SPMT040204 PD	4.7	2.4	0.4	2.3	TSB-22045	TXL-6
SPMT050204 PD	5.1	2.4	0.4	2.3		
SPMT060205 PD	6.2	2.5	0.5	2.5	TSB-22052	TXL-8
SPMT07T208 PD	7.5	2.8	0.7	2.8	TSB-25065	
SPMT090308 PD	9.2	3.3	0.8	3.4	TSB-30072	TXL-15
SPMT11T308 PD	11.0	4.0	0.8	4.0	TSB-35080	
SPMT130410 PD	13.0	4.5	1.0	4.5	TSB-40100	TXL-20
SPMT15M510 PD	15.2	5.0	1.0	5.5	TSB-50125	
SPMT180510 PD	18.2	5.5	1.0	6.0		

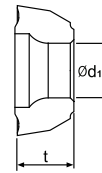
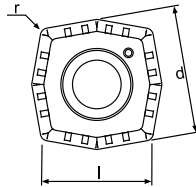

### ▶ XOMT

Code No.	치수 Dimension(mm)					부품 Parts	
	l	t	t	r	ød1	Screw	Driver
XOMT040204 PD	4.3	4.9	2.4	0.4	2.3	TSB-22045	TXL-6
XOMT050204 PD	4.8	5.4	2.4	0.4	2.3		
XOMT060204 PD	5.8	6.6	2.5	0.4	2.5	TSB-22052	TXL-8
XOMT07T205 PD	6.9	7.8	2.8	0.5	2.8	TSB-25065	
XOMT090305 PD	8.4	9.6	3.3	0.5	3.4	TSB-30072	TXL-15
XOMT11T306 PD	10.0	11.4	4.0	0.6	4.0	TSB-35080	
XOMT130406 PD	11.9	13.6	4.5	0.6	4.5	TSB-40100	TXL-20
XOMT15M508 PD	13.9	15.9	5.0	0.8	5.5	TSB-50125	
XOMT180508 PD	16.5	18.9	5.5	0.8	6.0		

Code No.		피삭재 Workpiece					KSD
외측 Peripheral Insert	내측 Central Insert	P	M	K	N	S	
SPMT040204 PD	XOMT040204 PD	◎	○	○	△	△	ø13.0~ø13.5
SPMT050204 PD	XOMT050204 PD	◎	○	○	△	△	ø14.0~ø16.0
SPMT060205 PD	XOMT060204 PD	◎	○	○	△	△	ø16.5~ø19.5
SPMT07T208 PD	XOMT07T205 PD	◎	○	○	△	△	ø20.0~ø23.5
SPMT090308 PD	XOMT090305 PD	◎	○	○	△	△	ø24.0~ø29.5
SPMT11T308 PD	XOMT11T306 PD	◎	○	○	△	△	ø30.0~ø35.0
SPMT130410 PD	XOMT130406 PD	◎	○	○	△	△	ø36.0~ø42.0
SPMT15M510 PD	XOMT15M508 PD	◎	○	○	△	△	ø43.0~ø50.0
SPMT180510 PD	XOMT180508 PD	◎	○	○	△	△	ø51.0~ø60.0

### ▶ 인서트 재종 일람표 Insert material type list

Workpiece Material	Symbol	Color	Cotting
P Steel	KT510	Gold	TiAlN
	KT520	Black	TiCN
M Stainless Steel	KT610	Gold	TiAlN
	KT620	Black	TiCN
K Cast Iron	KT710	Gold	TiAlN
	KT720	Black	TiCN



# ACCESSORIES

## CARTRIDGE

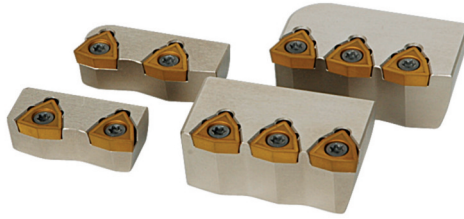

Inner	Outer	Insert	Screw	Driver	For Drill		
HSC-5965N	HSC-5965T				HSD-5965..D		
HSC-6570N	HSC-6570T	WCMX06T308	TSB-35090	T-15	HSD-6570..D		
HSC-7075N	HSC-7075T				HSD-7075..D		
HSC-7580N	HSC-7580T				HSD-7580..D		
VMC-045050N	VMC-045050T				WCMX030204	TSB-22045	T-6
VMC-050055N	VMC-050055T				VMD-050055		
VMC-055060N	VMC-055060T	WCMX040204	TSB-25055	T-8	VMD-055060		
VMC-060065N	VMC-060065T	WCMX050308	TSB-30070		VMD-060065, VLT·VSD-6065		
VMC-065070N	VMC-065070T				VMD-065070, VLT·VSD-6570		
VMC-070075N	VMC-070075T				VMD-070075, VLT·VSD-7075		
VMC-075080N	VMC-075080T			VMD-075080, VLT·VSD-7580			
VMC-080085N	VMC-080085T	WCMX06T308	TSB-35090	T-15	VMD-080085		
VMC-085090N	VMC-085090T				VMD-085090		
VMC-090095N	VMC-090095T				VMD-090095		
VMC-095100N	VMC-095100T				VMD-095100		
VMC-100105N	VMC-100105T	WCMX05308	TSB-30070	T-8	VMD-100105		
VMC-105110N	VMC-105110T	WCMX06T308	TSB-35090	T-15	VMD-105110		
VMC-110115N	VMC-110115T				VMD-110115		
VMC-115120N	VMC-115120T				VMD-115120		
VMC-120125N	VMC-120125T				VMD-120125		
VMC-125130N	VMC-125130T				VMD-125130		
VMC-130135N	VMC-130135T				VMD-130135		
VMC-135140N	VMC-135140T				VMD-135140		
VMC-140150N	VMC-140150T				VMD-140150		
VMC-150160N	VMC-150160T				WCMX080408	TSB-40110	VMD-150160
VMC-160170N	VMC-160170T						VMD-160170
VMC-170180N	VMC-170180T	VMD-170180					

※ Drill 카트리지는 드릴바디의 수명을 연장시키고 바깥쪽 카트리지 단면을 밀링 작업으로 직경을 (5mm/10mm)조절할 수 있습니다.

※ Please place an order shorten the length of outer cartridge if smaller diameter is needed.

(ex :  $\varnothing 77$ =by 1.5mm cutting MDC-075080T)





Inner	Outer	Insert	Screw	Driver	For Drill
HDC-5965N	HDC-5965T	WCMX06T308	TSB-35090	T-15	SFD·MCD-5965..D
MDC-045050N	MDC-045050T	WCMX030204	TSB-22045	T-6	MXD-045050
MDC-050055N	MDC-050055T				MXD-050055
MDC-055060N	MDC-055060T	WCMX040204	TSB-25055	T-8	MXD-055060
MDC-060065N	MDC-060065T	WCMX050308	TSB-30070	T-15	MXD-060065
MDC-065070N	MDC-065070T				MXD-065070, TSD·TMD-6570..D
MDC-070075N	MDC-070075T				MXD-070075, TSD·TMD-7075..D
MDC-075080N	MDC-075080T				MXD-075080, TSD·TMD-7580..D
MDC-080085N	MDC-080085T				MXD-080085, TSD·TMD-6570..D
MDC-085090N	MDC-085090T	WCMX06T308	TSB-35090	T-15	MXD-085090, TSD·TMD-7075..D
MDC-090095N	MDC-090095T				MXD-090095, TSD·TMD-7580..D
MDC-095100N	MDC-095100T				MXD-095100
MDC-100105N	MDC-100105T	WCMX050308	TSB-30070	T-8	MXD-100105
MDC-105110N	MDC-105110T	WCMX06T308	TSB-35090	T-15	MXD-105110
MDC-110115N	MDC-110115T				MXD-110115
MDC-115120N	MDC-115120T				MXD-115120
MDC-120125N	MDC-120125T				MXD-120125
MDC-125130N	MDC-125130T				MXD-125130
MDC-130135N	MDC-130135T				MXD-130135
MDC-135140N	MDC-135140T				MXD-135140
MDC-140150N	MDC-140150T				MXD-140150
MDC-150160N	MDC-150160T	WCMX080408	TSB-40110	T-15	MXD-150160
MDC-160170N	MDC-160170T				MXD-160170
MDC-170180N	MDC-170180T				MXD-170180

※ Drill 카트리지는 드릴바디의 수명을 연장시키고 바깥쪽 카트리지 단면을 밀링 작업으로 직경을 (5mm/10mm)조절할 수 있습니다.

※ Please place an order shorten the length of outer cartridge if smaller diameter is needed.  
(ex :  $\phi 77$ =by 1.5mm cutting MDC-075080T)



# ACCESSORIES

## CARTRIDGE



Inner	Outer	Insert	Insert Screw	Torx Driver	Clamping Bolt For Cartridge	For Drill
STC-V5055N	STC-V5055T	SPMX-090408	TSB-35090	T-15	M0512BH-W	STD-V5055..D
STC-V5560N	STC-V5560T					STD-V5560..D
STC-V6065N	STC-V6065T					STD-V6065..D
STC-V6570N	STC-V6570T	SPMX-110408	TSB-40100	T-15	M0614HC-W	STD-V6570..D
STC-V7075N	STC-V7075T					STD-V7075..D
STC-V7580N	STC-V7580T	SPMX-140512	TSB-50125	T-20		STD-V7580..D

※ 동일바디에 교환용 카트리지로 5mm범위 조절 가능합니다.(개별카트리지) 예 : STD-657040D(ø65~ø70 사용가능)

※ Adjustable within 5mm by exchangeable cartridge on the same drill body.(ex : STD-657040D(ø65~ø70 available))

Inner	Outer	Insert	Insert Screw	Driver	Clamping Bolt For Cartridge	Adjust Screw	For Drill
STC-5055N	STC-5051T	SPMX-090408	TSB-35090				STD-5055..D
	STC-5152T						
	STC-5253T						
	STC-5354T						
STC-5560N	STC-5455T	SPMX-090408	TSB-35090				STD-5060..D
	STC-5556T						
	STC-5657T						
	STC-5758T						
STC-6065N	STC-5859T	SPMX-110408	TSB-40100	T-15			STD-6065..D
	STC-5960T						
	STC-6061T						
	STC-6162T						
STC-6570N	STC-6263T	SPMX-110408	TSB-40100	T-15			STD-6570..D
	STC-6364T						
	STC-6465T						
	STC-6566T						
STC-7075N	STC-6667T	SPMX-110408	TSB-40100	T-15			STD-7075..D
	STC-6768T						
	STC-6869T						
	STC-6970T						
STC-7580N	STC-7071T	SPMX-140512	TSB-50125	T-20			STD-7580..D
	STC-7172T						
	STC-7273T						
	STC-7374T						
STC-7580N	STC-7475T	SPMX-140512	TSB-50125	T-20			STD-7580..D
	STC-7576T						
	STC-7677T						
	STC-7778T						
STC-7580N	STC-7879T	SPMX-140512	TSB-50125	T-20			STD-7580..D
	STC-7980T						

※ STC-V 카트리지와 STC카트리지는 서로 호환되지 않습니다.

※ It is not compatible with STC-V and STC





Inner	Outer	Insert	Insert Screw	Torx Driver	Clamping Bolt For Cartridge	For Drill
VLC-410450N	VLC-000410T	WCMX06T308	TSB-35078	T-15	M0510HC-W	VLT(VSD)-4145..D
	VLC-000420T					
	VLC-000430T					
	VLC-000440T					
	VLC-000450T					
VLC-460500N	VLC-000460T					
	VLC-000470T					
	VLC-000480T					
	VLC-000490T					
	VLC-000500T					
VLC-510550N	VLC-000510T	WCMX080408	TSB-40110	T-15	M0614HC-W	VLT(VSD)-5155..D
	VLC-000520T					
	VLC-000530T					
	VLC-000540T					
	VLC-000550T					
VLC-560590N	VLC-000560T					
	VLC-000570T					
	VLC-000580T					
	VLC-000590T					

※ 1mm단위 개별 카트리지가 사용으로 직경을 조절합니다.

※ Adjustable 1mm unit when you replace individual outer cartridge(1mm)

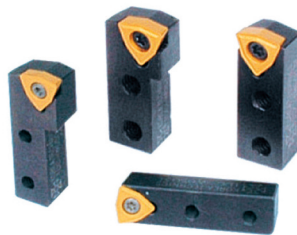

Inner	Outer	Insert	Insert Screw	Torx Driver	Clamping Bolt For Cartridge	For Drill
TDC-W0503N	TDC-W0503T	WCMX050308	TSB-30070	T-8	M0412BH-W	TPD-040..D~TPD-055..D
TDC-W06T3N	TDC-W06T3T	WCMX06T308	TSB-35090	T-15	M0616HC-W	TPD-060..D~TPD-110..D



# ACCESSORIES

## CARTRIDGE / WRENCH BOLT



### ▶ RBC-CC

Group	Code No.	Insert	미세조정볼트(M)	Screw	Driver	For Head
EMS25	RBC-028036-CC06	CCMT060204	M0306SS	TSB-25055	T-8	RBH-251437
EMS32	RBC-036047-CC06		M0408SS			RBH-321844
EMS40	RBC-047060-CC09	CCMT09T308	M0410SS	TSB-35080	T-15	RBH-402250
EMS50	RBC-060076-CC12	CCMT120408	M0514SS	TSB-50125	T-20	RBH-502855
EMS63	RBC-076098-CC12		M0515SS			RBH-633660
EMS80	RBC-098125-CC12		M0620SS			RBH-804576

### ▶ RBC-SC

Group	Code No.	Insert	미세조정볼트(M)	Screw	Driver	For Head
EMS25	RBC-028036-SC06	SCMT060204	M0306SS	TSB-25055	T-8	RBH-251437
EMS32	RBC-036047-SC06		M0408SS			RBH-321844
EMS40	RBC-047060-SC09	SCMT09T308	M0410SS	TSB-35080	T-15	RBH-402250
EMS50	RBC-060076-SC12	SCMT120408	M0514SS	TSB-50125	T-20	RBH-502855
EMS63	RBC-076098-SC12		M0515SS			RBH-633660
EMS80	RBC-098125-SC12		M0620SS			RBH-804576

### ● Construction System of Screw's Code No.

Code No.	Shape	Designation	Code No.	Shape	Designation
M□□□□BH		버튼헤드 스크류 Button Head Screw	M□□□□BH-W		버튼헤드 스크류+와샤 Button Head Screw+Washer
M□□□□HC		헤드캡 스크류 Headcap Screw	M□□□□HC-W		헤드캡 스크류+와샤 Headcap Screw +Washer
M□□□□SS		셋트 스크류 Set Screw	M□□□□SS-H		셋트 스크류 홀관통 Set Screw Hole
M□□□□CP		콘포인트 스크류 Cornpoint Screw	$M \square \square \square \square \square \square - \square$ <p style="text-align: center;">M size      Lenght      Shape      Note(etc.)</p>		



# ACCESSORIES

## PILOT DRILL / DRIVE RING / DRILL SLEEVE

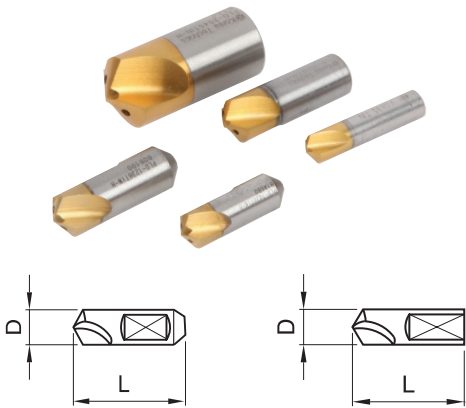

Code No.	D	L	For Drill
PLD-V0630 TiN	6	30	VLT, TSD, TMD
PLD-V0835 TiN	8	35	VLT, TSD, TMD
PLD-V1035 TiN-H	10	35	VMD, VLT, MXD, TSD, TMD
PLD-V1238 TiN-H	12	38	VMD, VLT, MXD, TSD, TMD
PLD-V1645 TiN-H	16	45	VMD, VLT, MXD, TSD, TMD
PLD-2045 TiN-H	20	45	VMD, MXD
PLD-2556 TiN-H	25	56	VMD, MXD
PLD-3068 TiN-H	30	68	VMD, MXD
PLD-0620 TiN	6	20	VSD, FXD
PLD-0825 TiN	8	25	VSD, FXD
PLD-1030 TiN-H	10	30	VSD, FXD
PLD-1236 TiN-H	12	36	VSD
PLD-1642 TiN-H	16	42	VSD

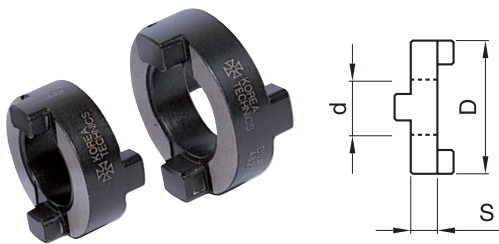

Code No.	D	d	S
DVR-281310	28	13	10
DVR-321610	32	16	10
DVR-402212	40	22	12
DVR-482712	48	27	12
DVR-583214	58	32	14
DVR-704014	70	40	14
DVR-805016	80	50	16

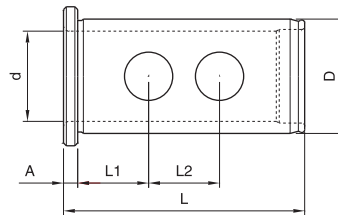

Code No.	D	d	L	L1	L2	A
DSL-322065	32	20	65	20	-	5
DSL-322565	32	25	65	20	20	
DSL-402075	40	20	75	20	-	
DSL-402575	40	25	75	20	25	
DSL-403275	40	32	75	20	25	
DSL-502095	50	20	95	35	-	
DSL-502595	50	25	95	35	-	
DSL-503295	50	32	95	35	35	
DSL-504095	50	40	95	35	35	

※ 드릴 슬리브(DSL)는 Weldon-B 타입 사이드락 아버(84~90페이지)와는 호환이 되지 않습니다.

※ Drill Sleeve(DSL) is not compatible with the Weldon-B type Side lock Arbor.(P.84~90)



# ACCESSORIES

## PULL STUD BOLT / DRIVERS

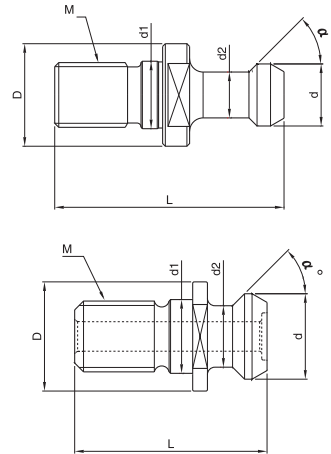

Code No.	D	d	d1	d2	M	L1	L	$\alpha^\circ$
PSB-40-1	23	15	17	10	M16	29	60	45°
PSB-40-2	23	15	17	10	M16	29	60	60°
PSB-40-3	23	15	17	10	M16	29	60	90°
PS-G51	22	18,796	17	12,446	M16	19,106	44,106	45°
PSB-50-1	38	23	25	17	M24	45	85	45°
PSB-50-2	38	23	25	17	M24	45	85	60°
PSB-50-3	38	23	25	17	M24	45	85	90°
PS-G41	37	28,956	25	20,828	M24	25,2	65,2	45°







TXL-6 TXL-8 TXL-15 TXL-20	
TXL-15 TXL-20	
TXL-20 TXL-25 TXL-30	
TXL-15 TXL-20	

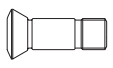
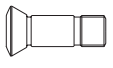
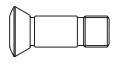

# ACCESSORIES

## CLAMPING SCREW FOR INDEXABLE INSERTS

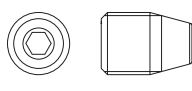

		Code No.	Description	Driver	Note
	DRILL & BORING	TSB-18045	M 1.8×4.5	T-6	
		TSB-20045	M 2.0×4.5	T-6	
		TSB-22045	M 2.2×4.5	T-6	
		TSB-22052	M 2.2×5.2	T-6	
		TSB-25055	M 2.5×5.5	T-8	
		TSB-25065	M 2.5×6.5	T-8	
		TSB-30070	M 3.0×7.0	T-8	
		TSB-30072	M 3.0×7.2	T-8	KSD(∅24~∅29.5)
		TSB-35078	M 3.5×7.8	T-15	VLT(∅41~∅59)
		TSB-35080	M 3.5×8.0	T-15	KSD, Boring Tool
		TSB-35090	M 3.5×9.0	T-15	
		TSB-40100	M 4.0×10.0	T-15	
		TSB-40110	M 4.0×11.0	T-15	
TSB-50125	M 5.0×12.5	T-20			
	CUTTER	CSB-6012	M 6.0×12.0	4	
		CSB-8012	M 8.0×12.0	5	
		CSB-8018	M 8.0×18.0	6	
	BALL NOSE CUTTER	TSB-319	M 4.0×8.0	T-15	
		TSB-243	M 5.0×11.0	T-20	
		TSB-390	M 4.0×8.5	T-15	
	FINISHING BALL CUTTER	TSB-391	M 5.0×9.0	T-20	
		TSB-392	M 5.0×13.0	T-20	
		TSB-393	M 5.0×15.5	T-20	
		TSB-394	M 6.0×20.5	T-20	
		TSB-395	M 8.0×25.0	T-30	
	FINISHING BALL CUTTER	TSB-5114	M 4.0×13.0	T-15	
		TSB-5214	M 5.0×16.0	T-15	
		TSB-5314	M 6.0×21.0	T-20	
		TSB-5414	M 8.0×25.0	T-20	
	FINISHING BALL CUTTER	TSB-5116	M 3.5×8.5	T-15	
		TSB-5216	M 5.0×10.0	T-15	
		TSB-5314	M 5.0×13.0	T-20	
		TSB-5414	M 6.0×17.5	T-20	
	MODULAR ARBOR	MTB-06085	M 6.0×8.5	3	
		MTB-08115	M 8.0×11.5	4	
		MTB-10145	M 10.0×14.5	5	
		MTB-12175	M 12.0×17.5	6	
		MTB-16225	M 16.0×22.5	8	
		MTB-16260	M 16.0×26.5	8	
	SHIM	CST-43			



# ACCESSORIES

## CLAMPING BOLTS FOR VMD

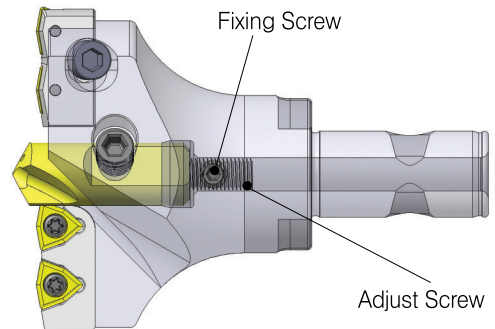
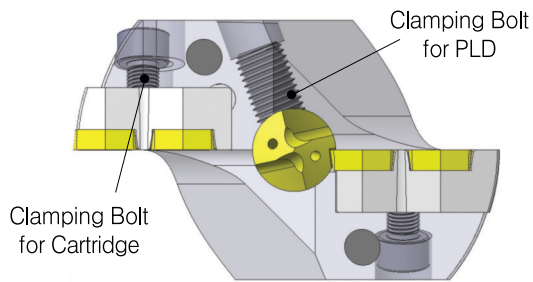

Code No.	Cartridge	Clamping Bolt For Cartridge	Pilot Drill	Clamping Bolt For PLD	Adjust Screw	Fixing Screw
VMD-045050	VMD-045050	M0410BH-W	PLD-V1035TiN-H	M0610SS	M0610SS-H	M0408SS
VMD-050055	VMD-050055					
VMD-055060	VMD-055060	M0512BH-W	PLD-V1238TiN-H	M0812SS	M0815SS-H	M0508SS
VMD-060065	VMD-060065					
VMD-065070	VMD-065070					
VMD-070075	VMD-070075			M0815SS		M0510SS
VMD-075080	VMD-075080	M0612HC-W	PLD-V1645TiN-H	M1015SS	M1015SS-H	M0610SS
VMD-080085	VMD-080085	M0614HC-W				
VMD-085090	VMD-085090	M0616HC-W	PLD-V1645TiN-H	M1020SS	M1018SS-H	M0612SS
VMD-090095	VMD-090095					
VMD-095100	VMD-095100					
VMD-100105	VMD-100105	M0818HC-W	PLD-2045TiN-H	M1220SS	M1220SS-H	M0615SS
VMD-105100	VMD-105100					
VMD-110115	VMD-110115			M1225SS	M1420SS-H	M0615SS
VMD-115120	VMD-115120	M0820HC-W				
VMD-120125	VMD-120125	M0825HC-W	PLD-2556TiN-H	M1425SS	M1420SS-H	M0615SS
VMD-125130	VMD-125130					
VMD-130135	VMD-130135					
VMD-135140	VMD-135140					
VMD-140150	VMD-140150					
VMD-150160	VMD-150160					
VMD-160170	VMD-160170		PLD-3068TiN-H	M1625SS	M1420SS-H	M0620SS
VMD-170180	VMD-170180					



# ACCESSORIES

## CLAMPING BOLTS FOR VLT

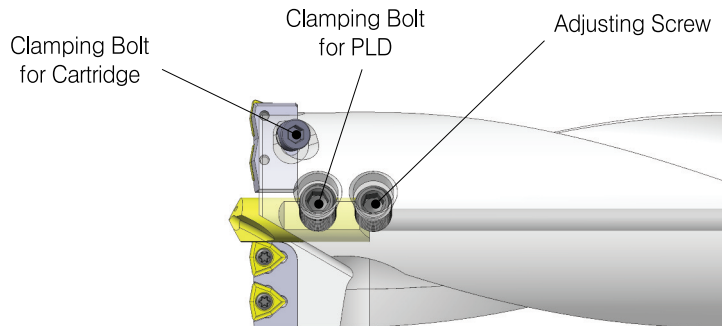

Code No.	카트리지 볼트 Cartridge			Pilot Drill				
	내측 Inner	외측 Outer	카트리지 볼트 Clamping Bolt For Cartridge	센터드릴 Pilot Drill	PLD 볼트 Clamping Bolt For PLD	조절 볼트 Adjusting Screw		
VLT~250..D	-	-	-	PLD-V0630TiN	M0508SS	M0510CP		
VLT~280..D					M0510SS			
VLT~290..D				PLD-V0835TiN	M0610SS	M0610CP		
VLT~300..D					M0612SS	M0616CP		
VLT~310..D					M0510HC-W	PLD-V1035TiN-H	M0812SS	M0812CP
VLT~340..D							M0815SS	M0816CP
VLT~350..D								
VLT~400..D								
VLT-4145..D	VLC-410450N	VLC-000410T VLC-000420T VLC-000430T VLC-000440T VLC-000450T	M0510HC-W	PLD-V1035TiN-H	M0812SS	M0812CP		
VLT-4650..D	VLC-460500N	VLC-000460T VLC-000470T VLC-000480T VLC-000490T VLC-000500T						
VLT-5155..D	VLC-510550N	VLC-000510T VLC-000520T VLC-000530T VLC-000540T VLC-000550T VLC-000560T	M0614HC-W	PLD-V1238TiN-H	M1015SS	M1016CP		
VLT-5659..D	VLC-56059N	VLC-000570T VLC-000580T VLC-000590T VLC-000600T						
VLT-6065..D	VMC-060065N	VLC-060065T					M0512BH-W	M1020SS
VLT-6570..D	VMC-065070N	VLC-065070T						
VLT-7075..D	VMC-070075N	VLC-070075T	M0612HC-W	PLD-V1645TiN-H	M1025SS	M1025CP		
VLT-7580..D	VMC-075080N	VLC-075080T						



# ACCESSORIES

## CLAMPING BOLTS FOR FXD, STD-V, HSD-V

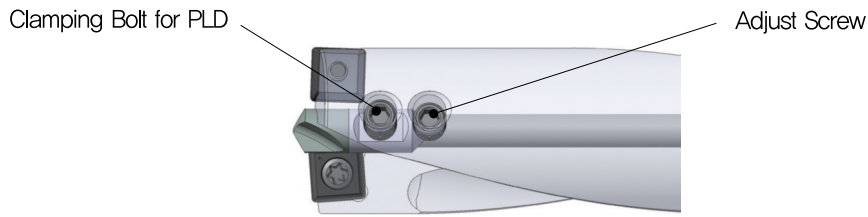

### ● FXD

Code No.	센터드릴 Pilot Drill		
	센터드릴 Pilot Drill	PLD 볼트 Clamping Bolt For PLD	조절 볼트 Adjusting Screw
FXD-180..D~FXD-220..D	PLD-0620TiN	M0506SS	M0506CP
FXD-225..D~FXD-250..D		M0508SS	M0508CP
FXD-255..D~FXD-300..D	PLD-0825TiN	M0608SS	M0610CP

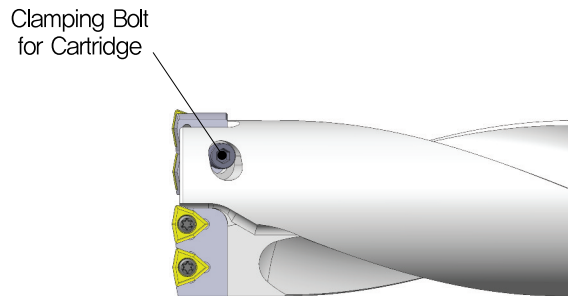
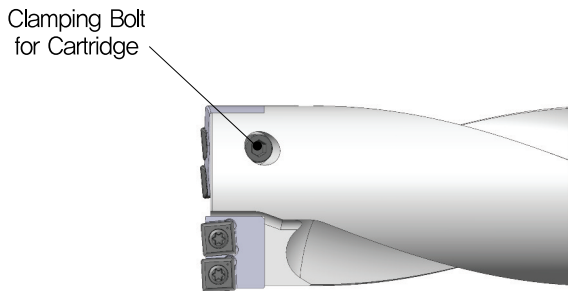

### ● STD-V

Code No.	카트리지 Cartridge		
	내측 Inner	외측 Outer	카트리지 볼트 Clamping Bolt For Cartridge
STD-V5055..D	STC-V5055N	STC-V5055T	M0512BH-W
STD-V5560..D	STC-V5560N	STC-V5560T	
STD-V6065..D	STC-V6065N	STC-V6065T	
STD-V6570..D	STC-V6570N	STC-V6570T	M0614HC-W
STD-V7075..D	STC-V7075N	STC-V7075T	
STD-V7580..D	STC-V7580N	STC-V7580T	

### ● HSD-V

Code No.	카트리지 Cartridge		
	내측 Inner	외측 Outer	카트리지 볼트 Clamping Bolt For Cartridge
HSD-V5965..D	HSC-5965N	HSC-5965T	M0512BH-W
HSD-V6570..D	HSC-6570N	HSC-6570T	
HSD-V7075..D	HSC-7075N	HSC-7075T	M0614HC-W
HSD-V7580..D	HSC-7580N	HSC-7580T	

