

V-MAX DRILL

VMD

DRILLING

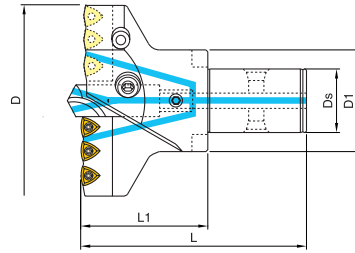
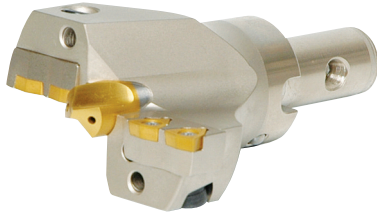

● MX Modular Shank Type

Code No.	치수 Dimension(mm)					센터드릴 Pilot Drill	카트리지 Cartridge	인서트 Insert	부품 Component	
	D	Ds	D1	L1	L				Screw	Driver
VMD-045050	45-50	13	28	50	85	PLD-V1035 TiN-H	VMC-045050N/T VMC-050055N/T	WCMX030204	TSB-22045	TXL-6
VMD-055060	55-60	16	32	60	100					
VMD-060065	60-65	16	32	60	100	PLD-V1238 TiN-H	VMC-060065N/T VMC-065070N/T	WCMX050308	TSB-30070	TXL-8
VMD-070075	70-75	22	40	70	115					
VMD-075080	75-80	22	40	70	115	PLD-V1645 TiN-H	VMC-075080N/T VMC-080085N/T VMC-085090N/T VMC-090095N/T	WCMX06T308	TSB-35090	TXL-15
VMD-080085	80-85	22	40	70	115					
VMD-085090	85-90	27	48	70	120					
VMD-090095	90-95	27	48	70	120					
VMD-095100	95-100	27	48	70	120	PLD-V2045 TiN-H	VMC-100105N/T VMC-105110N/T	WCMX050308	TSB-30070	TXL-8
VMD-100105	100-105	32	58	80	130					
VMD-105110	105-110	32	58	80	130	PLD-V2556 TiN-H	VMC-110115N/T VMC-115120N/T VMC-120125N/T	WCMX06T308	TSB-35090	TXL-15
VMD-110115	110-115	32	58	80	130					
VMD-115120	115-120	40	70	90	145					
VMD-120125	120-125	40	70	90	145	PLD-V3068 TiN-H	VMC-125130N/T VMC-130135N/T VMC-135140N/T VMC-140150N/T	WCMX080408	TSB-40110	TXL-15
VMD-125130	125-130	40	70	90	145					
VMD-130135	130-135	40	70	90	145					
VMD-135140	135-140	40	70	90	145					
VMD-140150	140-150	50	80	100	160	PLD-V3068 TiN-H	VMC-150160N/T VMC-160170N/T VMC-170180N/T	WCMX080408	TSB-40110	TXL-15
VMD-150160	150-160	50	80	100	160					
VMD-160170	160-170	50	80	100	160					
VMD-170180	170-180	50	80	100	160					

- ※ 바디표면을 특수표면처리하여 내마모성 및 수명이 길어졌습니다.
- ※ MX Modular System으로 원하는 가공깊이 조절가능.
- ※ V-MAX 드릴 헤드는 최대직경으로 공급됩니다.
- ※ WCMX 인서트는 [108페이지](#)를 참조해주세요.

- ※ The drill body treated by forging was much solid and much stronger in impact.
- ※ The connecting strength by the MX modular system is excellent and the drilling depth is freely adjustable by connecting MXB, MXR and MXA.
- ※ Drill head is supplied with Max. diameter
- ※ Please refer to the [page108](#) regarding WCMX insert.

- VMD 드릴 가공 동영상을 보시려면, 오른쪽 QR코드를 스캔하세요.
- Please scan the QR code if you want to see VMD drill testing sample video.



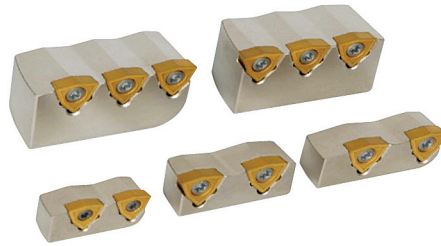

CARTRIDGE

Drilling Range	Inner	Outer	인서트 Insert	No.of Insert	부품 Component	
					Screw	Driver
45-50	VMC-045050N	VMC-045050T	WCMX030204	2	TSB-22045	TXL-6
50-55	VMC-050055N	VMC-050055T	WCMX040204	2	TSB-25055	TXL-8
55-60	VMC-055060N	VMC-055060T	WCMX040204	2	TSB-25055	
60-65	VMC-060065N	VMC-060065T	WCMX050308	2	TSB-30070	
65-70	VMC-065070N	VMC-065070T	WCMX050308	2	TSB-30070	
70-75	VMC-070075N	VMC-070075T	WCMX050308	2	TSB-30070	
75-80	VMC-075080N	VMC-075080T	WCMX06T308	2	TSB-35090	TXL-15
80-85	VMC-080085N	VMC-080085T				
85-90	VMC-085090N	VMC-085090T				
90-95	VMC-090095N	VMC-090095T				
95-100	VMC-095100N	VMC-095100T				
100-105	VMC-100105N	VMC-100105T	WCMX050308	3	TSB-30070	TXL-8
105-110	VMC-105110N	VMC-105110T	WCMX06T308	3	TSB-35090	TXL-15
110-115	VMC-110115N	VMC-110115T				
115-120	VMC-115120N	VMC-115120T				
120-125	VMC-120125N	VMC-120125T				
125-130	VMC-125130N	VMC-125130T				
130-135	VMC-130135N	VMC-130135T				
135-140	VMC-135140N	VMC-135140T				
140-150	VMC-140150N	VMC-140150T				
150-160	VMC-150160N	VMC-150160T				
160-170	VMC-160170N	VMC-160170T				
170-180	VMC-170180N	VMC-170180T	WCMX080408	3	TSB-40110	

※ VMD 카트리지는 바디의 수명을 연장시키고 바깥쪽 카트리지를 밀링 작업으로 직경을(5mm)조절할 수 있습니다.

※ Please place an order shorten the length of outer cartridge if smaller dia. is needed.(ex: $\phi 77$ =by1.5mm cutting MDC-075080T)

PILOT DRILL

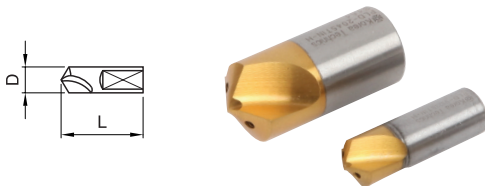

Code No.	치수 Dimension(mm)	
	D	L
PLD-V1035 TiN-H	10	35
PLD-V1238 TiN-H	12	38
PLD-V1645 TiN-H	16	45
PLD-2045 TiN-H	20	45
PLD-2556 TiN-H	25	56
PLD-3068 TiN-H	30	68

※ ex:PLD-2556 TiN-H(25TiN coated oil hole)

DRIVE RING



Code No.	치수 Dimension(mm)		
	D	d	S
DVR-281310	28	13	10
DVR-321610	32	16	10
DVR-402212	40	22	12
DVR-482712	48	27	12
DVR-583214	58	32	14
DVR-704014	70	40	14
DVR-805016	80	50	16

V-MAX DRILL

MXB / MXR

DRILLING

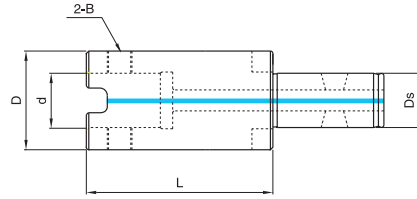

● MX Extension

▶ MXB

Code No.	치수 Dimension(mm)				B	Drive Ring
	D	d	L	Ds		
MXB-2813115	28	13	115	13	MTB-08115	DVR-281310
MXB-2813150			150			
MXB-2813200			200			
MXB-2813300			300			
MXB-3216115	32	16	115	16	MTB-08115	DVR-321610
MXB-3216200			200			
MXB-3216300			300			
MXB-4022113	40	22	113	22	MTB-10145	DVR-402212
MXB-4022200			200			
MXB-4022300			300			
MXB-4827113	48	27	113	27	MTB-12175	DVR-482712
MXB-4827200			200			
MXB-4827300			300			
MXB-5832186	58	32	186	32	MTB-12195	DVR-583214
MXB-5832300			300			
MXB-7040186			186			
MXB-7040300	70	40	300	40	MTB-16260	DVR-704014
MXB-7040500			500			
MXB-8050204			204			
MXB-8050300	80	50	300	50	MTB-16260	DVR-805016
MXB-8050500			500			

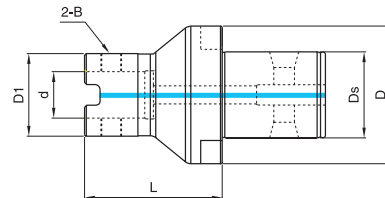

● MX Reducer

▶ MXR

Code No.	치수 Dimension(mm)					B	D1/Drive Ring	D/Drive Ring
	Ds	d	L	D	D1			
MXR-1613100	16	13	100	32	28	MTB-08115	DVR-281310	DVR-321610
MXR-2216100	22	16	100	40	32	MTB-08115	DVR-321610	DVR-402212
MXR-2722100	27	22	100	48	40	MTB-10145	DVR-402212	DVR-482712
MXR-3213100	32	13	100	58	28	MTB-08115	DVR-281310	DVR-583214
MXR-3216100	32	16	100	58	32	MTB-08115	DVR-321610	DVR-583214
MXR-3222100	32	22	100	58	40	MTB-10145	DVR-402212	DVR-583214
MXR-3227100	32	27	100	58	48	MTB-12175	DVR-482712	DVR-583214
MXR-4032100	40	32	100	70	58	MTB-12195	DVR-583214	DVR-704014
MXR-5013080	50	13	80	80	28	MTB-08115	DVR-281310	DVR-805016
MXR-5016080	50	16	80	80	32	MTB-08115	DVR-321610	DVR-805016
MXR-5022080	50	22	80	80	40	MTB-10145	DVR-402212	DVR-805016
MXR-5027080	50	27	80	80	48	MTB-12175	DVR-482712	DVR-805016
MXR-5032080	50	32	80	80	58	MTB-12195	DVR-583214	DVR-805016
MXR-5040150	50	40	150	80	70	MTB-16260	DVR-704014	DVR-805016

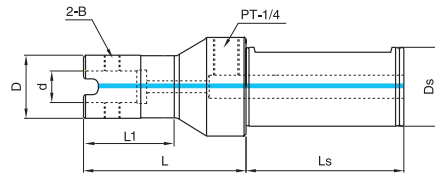

● MX + CYLINDRICAL Adaptor

▶ MXA

Code No.	치수 Dimension(mm)						B	Drive Ring
	Ds	d	L	L1	D	Ls		
MXA-3213115	32	13	115	77	28	70	MTB-08115	DVR-281310
MXA-3213200		13	200	165	28			
MXA-3213300		13	300	265	28			
MXA-4016125	40	16	125	86	32	80	MTB-10145	DVR-321610
MXA-1016200		16	200	161	32			
MXA-4016300		16	300	261	32			
MXA-4022148		22	148	109	40			
MXA-4022200		22	200	161	40			
MXA-4022300		22	300	261	40			
MXA-4027168		27	168	133	48			
MXA-4027300		27	300	265	48			
MXA-4032186		32	186	151	58			
MXA-4032300		32	300	265	58			
MXA-W5040186	50	40	186	151	70	80	MTB-16260	DVR-704014
MXA-W5040300		40	300	265	70			
MXA-W5050184		50	184	149	80			
MXA-W5050300		50	300	265	80			

※ MX모듈러 시스템을 사이드락 타입으로 변환시켜주는 어댑터입니다.
 ※ It is a Adaptor that converts the MX modular system to Side lock Type.

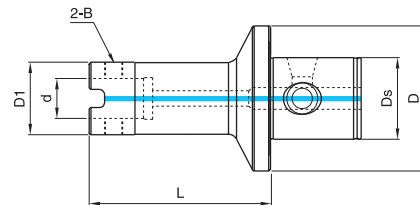

● MX + EXT Adaptor

▶ MXE

Code No.	치수 Dimension(mm)					B	D1/Drive Ring				
	Ds	d	L	D	D1						
MXE-3613100	36	13	100	63	28	MTB-08115	DVR-281310				
MXE-3616100		16			32			MTB-08115	DVR-321610		
MXE-3622100		22			40					MTB-10145	DVR-402212
MXE-3627100		27			48						
MXE-3632100		32			58			MTB-12195	DVR-583214		
MXE-4513100	45	13	80	28	MTB-08115	DVR-281310					
MXE-4516100		16		32			MTB-08115	DVR-321610			
MXE-4522100		22		40					MTB-10145	DVR-402212	
MXE-4527100		27		48							MTB-12175
MXE-4532100		32		58			MTB-12195	DVR-583214			

※ MX모듈러 시스템을 EXT모듈러 시스템으로 변환시켜주는 어댑터입니다.
 ※ It is a Adaptor that converts the MX modular system to EXT modular system.



새로워진 V-MAX DRILL! IMPROVED V-MAX DRILL!



- 드릴바디를 단조처리하여 더욱 단단하고 충격에 강하다!
The drill body treated by forging was much solidier and much stronger in impact.

- 바디표면을 특수표면처리하여 내마모성 및 수명이 길어졌다!
The especially treated surface of body make the inner-abrasion much better and the life make much longer

- 더욱 안정된 설계로 제작되어 MXD보다 드릴링이 안정되어 경제성이 뛰어나다!
As this drill was designed more stably, this drill is steady of drilling and is good of economical efficiency.

- 가공직경 $\phi 45 \sim \phi 180$ 이며, 가공깊이는 MX modular system으로 자유롭게 조절할 수 있다!
Drilling diameters are from 45mm to 180mm and the drilling depth is freely adjustable by using the MX modular system

- 카트리지(VMC)타입으로 드릴바디의 수명을 연장시키고 가공직경을 조절할 수 있다!
As this drill is cartridge(VMC)type, the drilling diameters are adjustable.

- 안정된 재고관리로 원하시는 제품을 신속히 사용할 수 있다!
We can supply to customers promptly by kepping stable stocks.

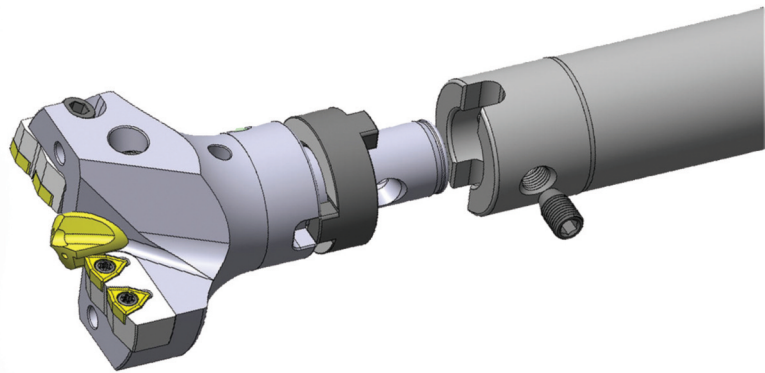

- MX 모듈러 시스템에 의한 체결방식으로 체결강성이 뛰어나며, 가공깊이를 MXB, MXR, MXA등으로 연결하여 가공깊이를 자유롭게 조절할 수 있습니다.

- The connecting strength by the MX modular system is excellent and the drilling depth is freely adjustable by connecting MXB, MXR and MXA.

POWER REQUIRMENTS

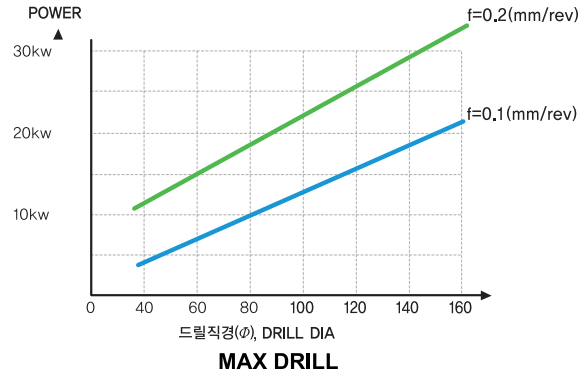
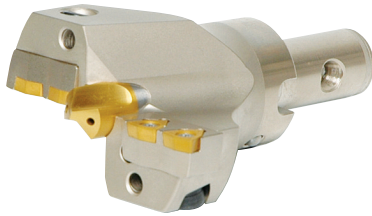

파일럿 드릴(PLD)셋팅 높이 Pilot drill(PLD) setting

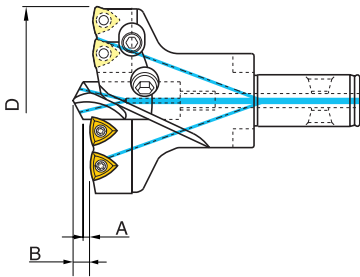

드릴경D	2~4×D		4~6×D		6~8×D	
	A	B	A	B	A	B
45-55	1.6	4.0	1.8	4.2	2.0	4.4
55-75	1.8	5.4	2.0	5.6	2.2	5.8
75-100	2.2	6.5	2.5	6.8	2.8	7.1
100-120	2.4	7.7	2.8	8.1	3.2	8.5
120-170	3.2	9.9	3.6	10.3	4.0	10.7
170-180	3.5	12.2	3.9	12.6	4.3	13.0

VMD(MXD)가공직경 조절방법 THE DIAMETER ADJUSTING PROCEDURES OF VMD(MXD)

- 외측카트리지를 카트리지 클램핑 볼트를 풀어 바디에서 이탈 시킵니다.
Loosen the clamping bolt of the outer cartridge and remove it from the drill body.
- 외측카트리지의 측면 밀착부를 가공하려는 직경을 계산하여 밀링작업을합니다.
Cut off the inside part, the contacted side of the outer cartridge by milling after calculating the drilling diameter.
- 컷팅된 외측카트리지의 날카로운 모서리면을 모따기 처리합니다.
Slick the sharp corner of the cut cartridge.
- 외측카트리지를 틈이 발생되지 않도록 바디에 밀착시키면서 카트리지 클램핑 볼트로 단단히 고정합니다.
Adhere the cartridge closely to the drill body not happen gap and fix the cartridge with bolt tightly.

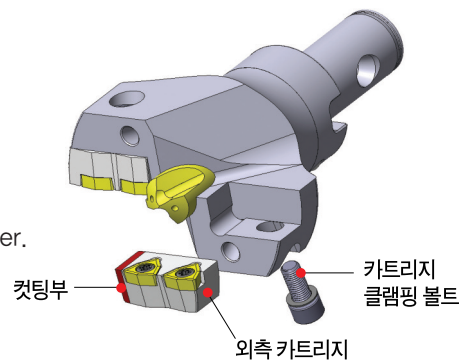

Example VMD-135140를 $\phi 136$ 로 셋팅한다면, 기본직경은 $\phi 140$ 이므로 $\phi 140 - \phi 136 = 4 \rightarrow 4 \div 2 = 2$ (반지름으로 계산) 2mm컷팅합니다.

If setting VMD-135140 to $\phi 136$ seat
The standard drill diameter is $\phi 140$ so $\phi 140 - \phi 136 = 4 \rightarrow 4 \div 2 = 2$ (calculation by semidiameter)
2mm is cut off.