

Pneumatic Robotic Hand

Parallel Robotic Hand Gripper

Model WPA



Compact Parallel Robotic Hand with High-Gripping Force Ability to Install Auto Switches for Gripper Detection

- **Wider Stroke**

Wider opening and closing stroke allows for gripping various sizes of workpieces.



- **Compact Body with High Gripping Force**

It has a compact body with stable and high gripping force. Reduction in size allows for less interference and optimal space utilization.

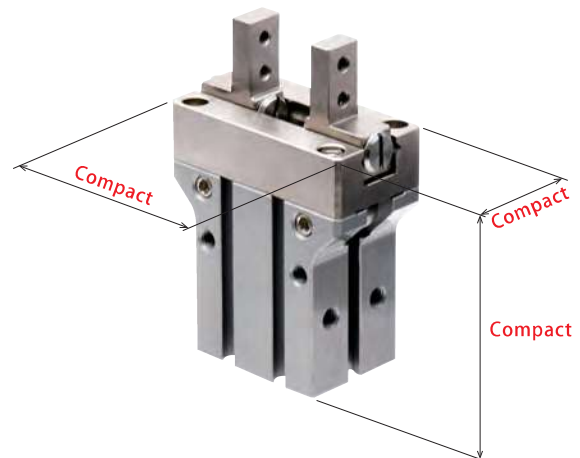

- **High Accuracy and High Rigidity**

The cross roller guide function allows for high rigidity and high accuracy opening/closing function.
Repeatability: $\pm 0.01\text{mm}$

- **Light Weight**

Reduced size and weight allows for best use of the robotic payload.

- **Long Operational Life**

Solid internal features provide for excellent durability.

- **Auto Switch Capability**

Easy to install and adjust auto switches for gripper detection.

Model No. Indication

WPA 016 0 - A2 S

1 2 3 4

※ Only 1 2 are marked on the product.

Please indicate the specifications of 3 4 if you need switches.

1 Cylinder Inner Diameter

012 : ϕ 12 mm

016 : ϕ 16 mm

020 : ϕ 20 mm

025 : ϕ 25 mm

2 Design No.

0 : Revision Number

Specifications

Model No.		WPA0120	WPA0160	WPA0200	WPA0250
Cylinder Inner Diameter	mm	12	16	20	25
Gripping Force ^{※1} (Air Pressure : At 0.5MPa)	Closing Side	N	29	63	88
	Opening Side	N	39	73	105
Full Stroke	mm	6	8	12	16
Repeatability ^{※2}	mm	± 0.01			
Stroke Error	mm	Opened State : $-0.5 \sim +1$ / Closed State : $-1 \sim +0.5$			
Allowable Gripper Length L (Air Pressure : at 0.5MPa) ^{※3}	mm	30	40	50	60
Allowable Gripper Offset Distance H (Air Pressure : at 0.5MPa) ^{※3}	mm	12	15	25	35
Maximum Cycle / min.		90			
Maximum Operating Pressure	MPa	0.7			
Minimum Operating Pressure	MPa	0.2			
Withstanding Pressure	MPa	1.05			
Operating Temperature Range	°C	5 ~ 60			
Usable Fluid		Dry Air			
Weight	kg	0.07	0.17	0.32	0.56

Notes : ※1. Gripping force indicates the calculated value based on the gripper length (L).

※2. Repeatability under the same condition (no load).

※3. L : Allowable Gripper Length (mm), H : Allowable Gripper Offset Distance (mm). (Air Pressure : at 0.5MPa)

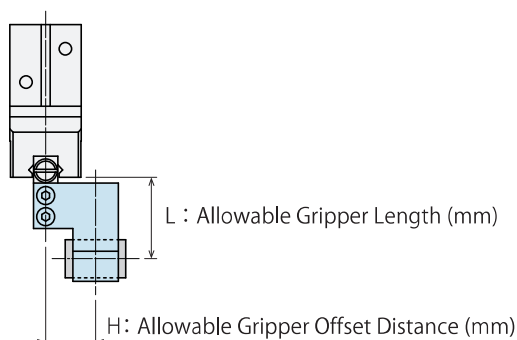
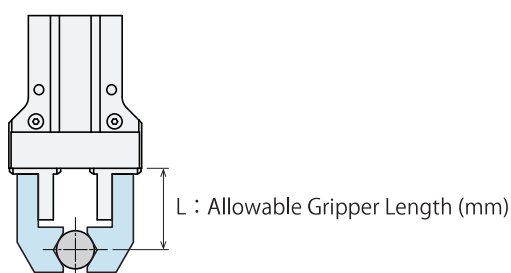

3 Auto Switch Type

Blank : Without Auto Switch

A2 : 2-Wire Reed Auto Switch (Cable: 1m)

A2L : 2-Wire Reed Auto Switch (Cable: 3m)

A2V : L-Shaped 2-Wire Reed Auto Switch (Cable: 1m)

A2VL : L-Shaped 2-Wire Reed Auto Switch (Cable: 3m)

B2 : 3-Wire Solid State Auto Switch (Cable: 1m)

B2L : 3-Wire Solid State Auto Switch (Cable: 3m)

B3 : L-Shaped 3-Wire Solid State Auto Switch (Cable: 1m)

B3L : L-Shaped 3-Wire Solid State Auto Switch (Cable: 3m)

※ Please refer to P.405 ~ P.414 for details on auto switches.

4 Number of Auto Switches[※]

Blank : 2

S : 1

※ Only when selecting the auto switch option other than 3 **Blank**.

Locating
+
Clamp

Locating

Hand • Clamp

Support

Valve • Coupler

Cautions • Others

Pallet Gripper

WVA

Locating
Pin Clamp

SWP

High-Power
Pull Stud Clamp

WPT

JES

FA Pneumatic
Hole Clamp

WKH

Lifting
Hole Clamp

SWJ

Ball Lock
Cylinder

WKA

Pneumatic
Robotic Hands

WPW-C

WPS-C

WPA

WPH

WPP

WPQ

Auto Switch
Proximity Switch

JEP

High-Power Pneumatic
Hole Clamp

SWE

High-Power Pneumatic
Swing Clamp

WHE

High-Power Pneumatic
Link Clamp

WCE

Pneumatic
Hole Clamp

SWA

Pneumatic
Swing Clamp

WHA

Double Piston
Pneumatic
Swing Clamp

WHD

Pneumatic
Link Clamp

WCA

Air Flow
Control Valve

BZW

Manifold
Block

WHZ-MD

● Gripping Force Performance Curve : Closing Side

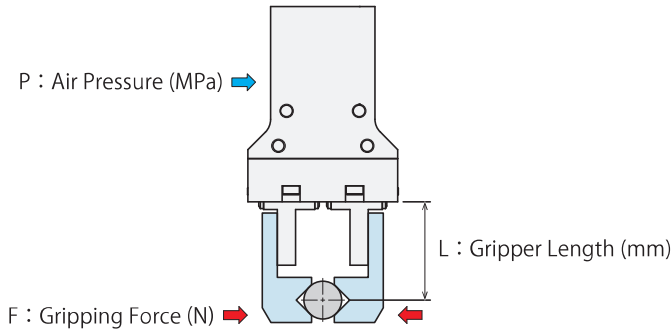

Notes:

1. This chart and graph show the relationship among: F:Gripping Force (N), P: Air Pressure (MPa) and L:Gripper Length (mm).
2. Operation in the non-usable range may cause deformation, galling or air leakage.

WPA0120				(N)
Air Pressure (MPa)	Gripper Length L (mm)			
	10	20	30	
0.7	42	41	39	
0.5	30	29	28	
0.2	12	11	10	

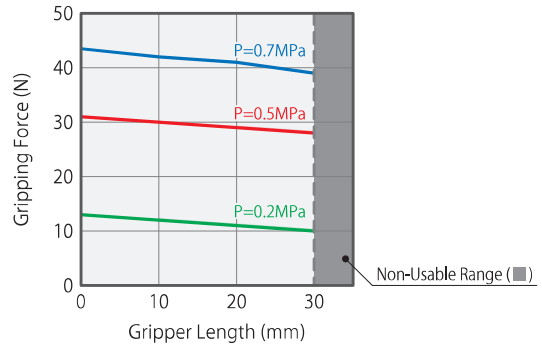

WPA0160					(N)
Air Pressure (MPa)	Gripper Length L (mm)				
	10	20	30	40	
0.7	89	87	85	82	
0.5	64	62	61	59	
0.2	26	25	24	23	

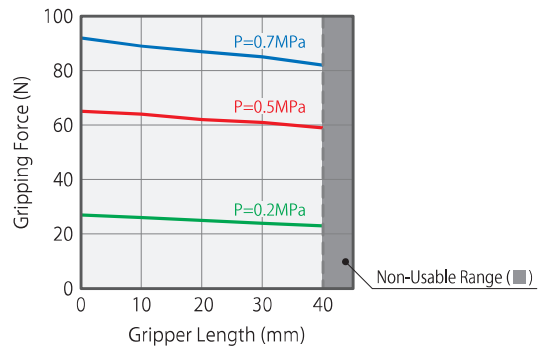

WPA0200						(N)
Air Pressure (MPa)	Gripper Length L (mm)					
	10	20	30	40	50	
0.7	128	125	122	120	117	
0.5	91	89	87	86	84	
0.2	37	36	35	34	33	

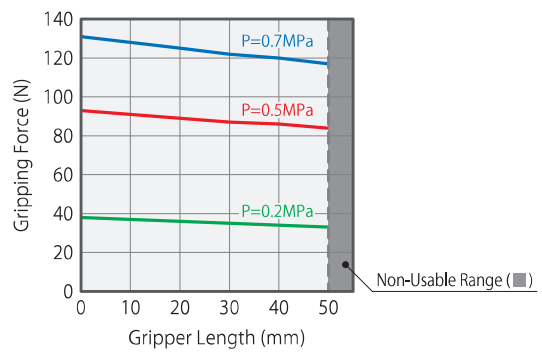

WPA0250							(N)
Air Pressure (MPa)	Gripper Length L (mm)						
	10	20	30	40	50	60	
0.7	193	190	186	183	180	177	
0.5	138	135	133	131	129	127	
0.2	55	54	53	52	51	50	

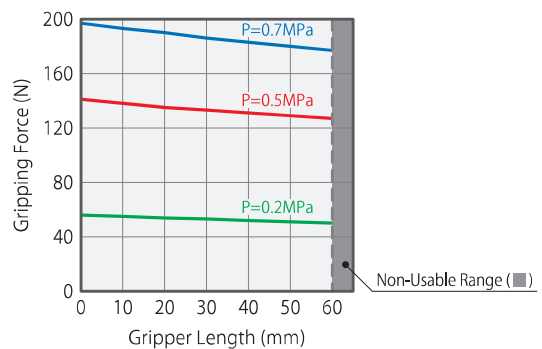

● Gripping Force Performance Curve : Opening Side

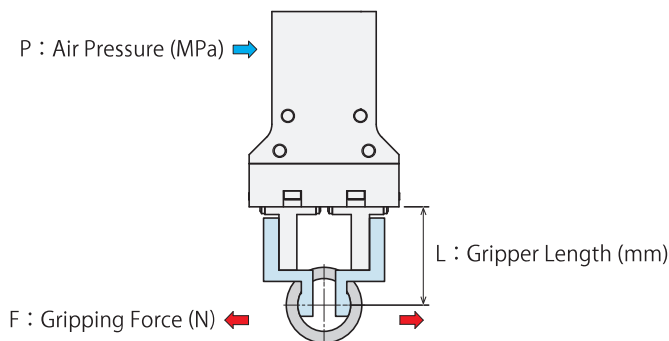

WPA0120 (N)				
Air Pressure (MPa)	Gripper Length L (mm)			
	10	20	30	
0.7	56	54	52	
0.5	40	39	37	
0.2	16	15	14	

WPA0160 (N)					
Air Pressure (MPa)	Gripper Length L (mm)				
	10	20	30	40	
0.7	104	101	99	96	
0.5	74	72	70	68	
0.2	30	29	28	27	

WPA0200 (N)						
Air Pressure (MPa)	Gripper Length L (mm)					
	10	20	30	40	50	
0.7	152	149	146	143	141	
0.5	109	106	104	102	100	
0.2	43	42	41	40	39	

WPA0250 (N)							
Air Pressure (MPa)	Gripper Length L (mm)						
	10	20	30	40	50	60	
0.7	230	226	222	218	215	211	
0.5	164	161	158	156	153	150	
0.2	65	64	63	62	61	60	

Notes:

- This chart and graph show the relationship among: F: Gripping Force (N), P: Air Pressure (MPa) and L: Gripper Length (mm).
- Operation in the non-usable range may cause deformation, galling or air leakage.

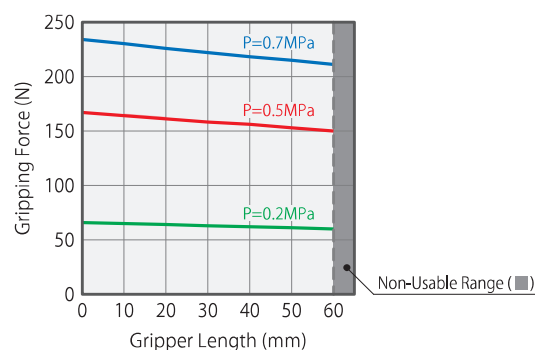
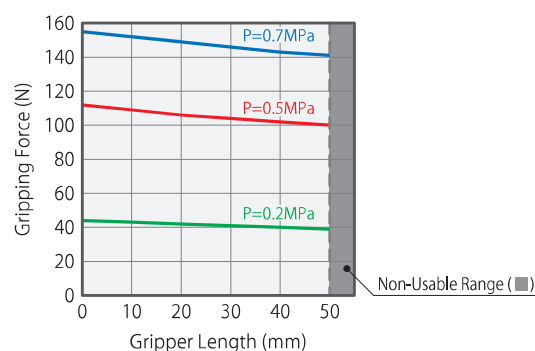
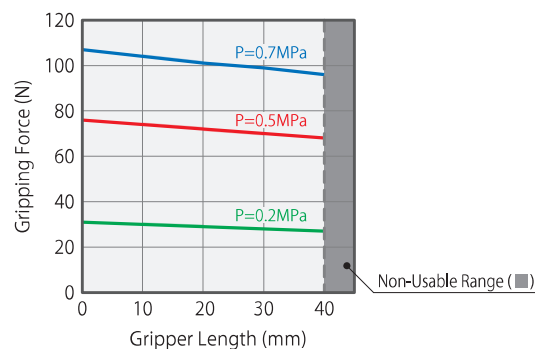
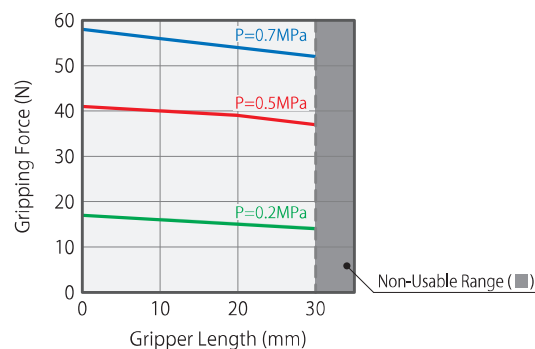
Locating
+
Clamp

Locating

Hand • Clamp

Support

Valve • Coupler

Cautions • Others

Pallet Gripper

WVA

Locating
Pin Clamp

SWP

High-Power
Pull Stud Clamp

WPT

JES

FA Pneumatic
Hole Clamp

WKH

Lifting
Hole Clamp

SWJ

Ball Lock
Cylinder

WKA

Pneumatic
Robotic Hands

WPW-C

WPS-C

WPA

WPH

WPP

WPQ

Auto Switch
Proximity Switch

JEP

High-Power Pneumatic
Hole Clamp

SWE

High-Power Pneumatic
Swing Clamp

WHE

High-Power Pneumatic
Link Clamp

WCE

Pneumatic
Hole Clamp

SWA

Pneumatic
Swing Clamp

WHA

Double Piston
Pneumatic
Swing Clamp

WHD

Pneumatic
Link Clamp

WCA

Air Flow
Control Valve

BZW

Manifold
Block

WHZ-MD

● Allowable Load and Allowable Moment

Model No.	Fv : Allowable Vertical Load (N)	Maximum Allowable Moment (N · m)		
		Mp : Pitch Moment	My : Yaw Moment	Mr : Roll Moment
WPA0120	79	0.28	0.28	0.63
WPA0160	141	0.67	0.67	1.77
WPA0200	169	0.84	0.84	2.61
WPA0250	265	1.65	1.65	4.93

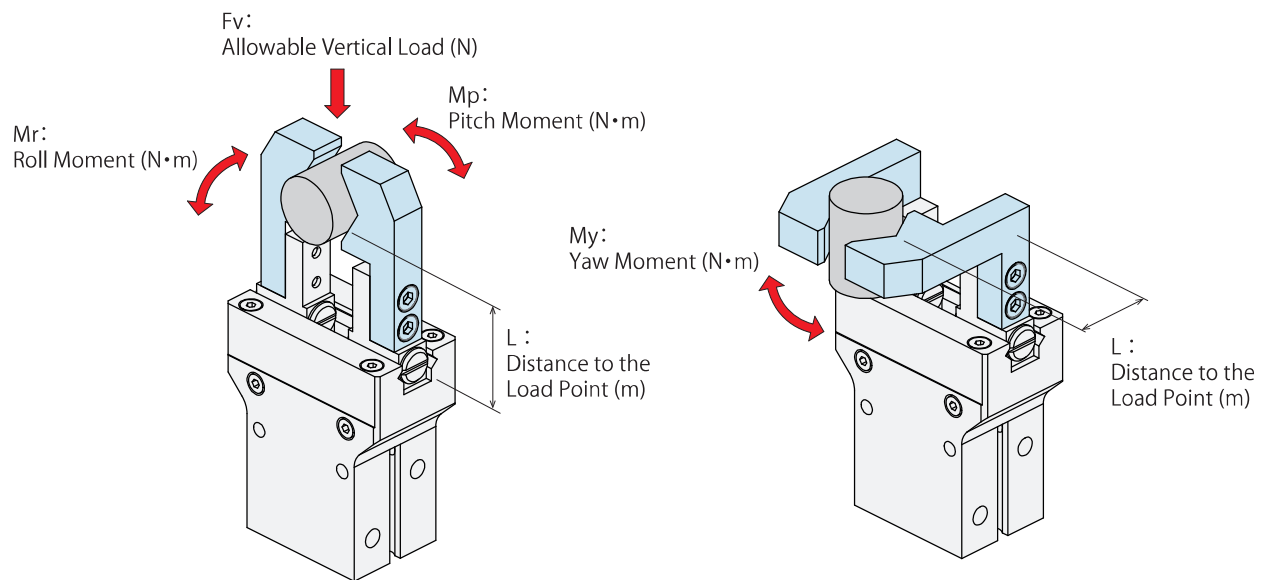

Notes :

1. The values on the list are the static values.
2. The arrows show the direction of Fv : Allowable Vertical Load (N), Mp : Pitch Moment (N · m), My : Yaw Moment (N · m) and Mr : Roll Moment (N · m).

● Allowable Load Calculation Formula

$$F : \text{Allowable Load (N)} = \frac{M : \text{Maximum Allowable Moment (N} \cdot \text{m)}}{L : \text{Distance to the Load Point (m)}}$$

**Locating
+
Clamp**
Locating
Hand • Clamp
Support
Valve • Coupler
Cautions • Others

Pallet Gripper

WVA

 Locating
Pin Clamp

SWP

 High-Power
Pull Stud Clamp

WPT

JES

 FA Pneumatic
Hole Clamp

WKH

 Lifting
Hole Clamp

SWJ

 Ball Lock
Cylinder

WKA

**Pneumatic
Robotic Hands**

WPW-C

WPS-C

WPA

WPH

WPP

WPQ

 Auto Switch
Proximity Switch

JEP

 High-Power Pneumatic
Hole Clamp

SWE

 High-Power Pneumatic
Swing Clamp

WHE

 High-Power Pneumatic
Link Clamp

WCE

 Pneumatic
Hole Clamp

SWA

 Pneumatic
Swing Clamp

WHA

 Double Piston
Pneumatic
Swing Clamp

WHD

 Pneumatic
Link Clamp

WCA

 Air Flow
Control Valve

BZW

 Manifold
Block

WHZ-MD

External Dimensions : WPA0120

※ The drawing shows the opened state of WPA0120.

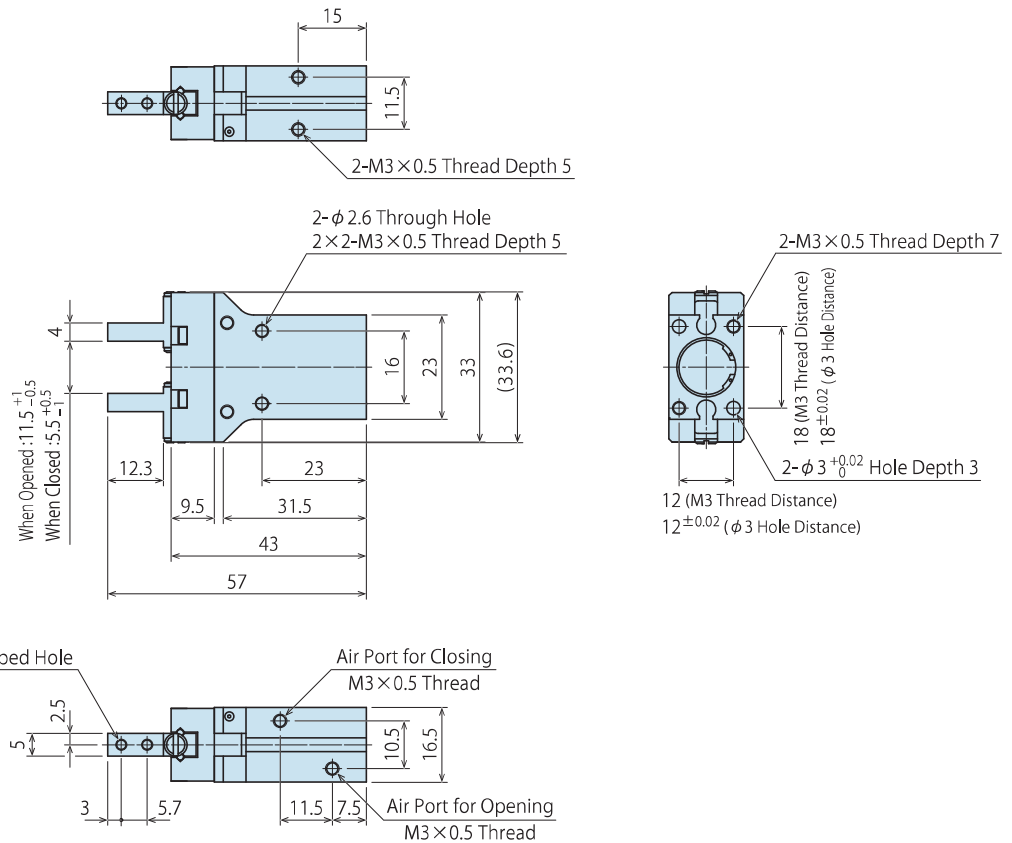

External Dimensions : WPA0160

※ The drawing shows the opened state of WPA0160.

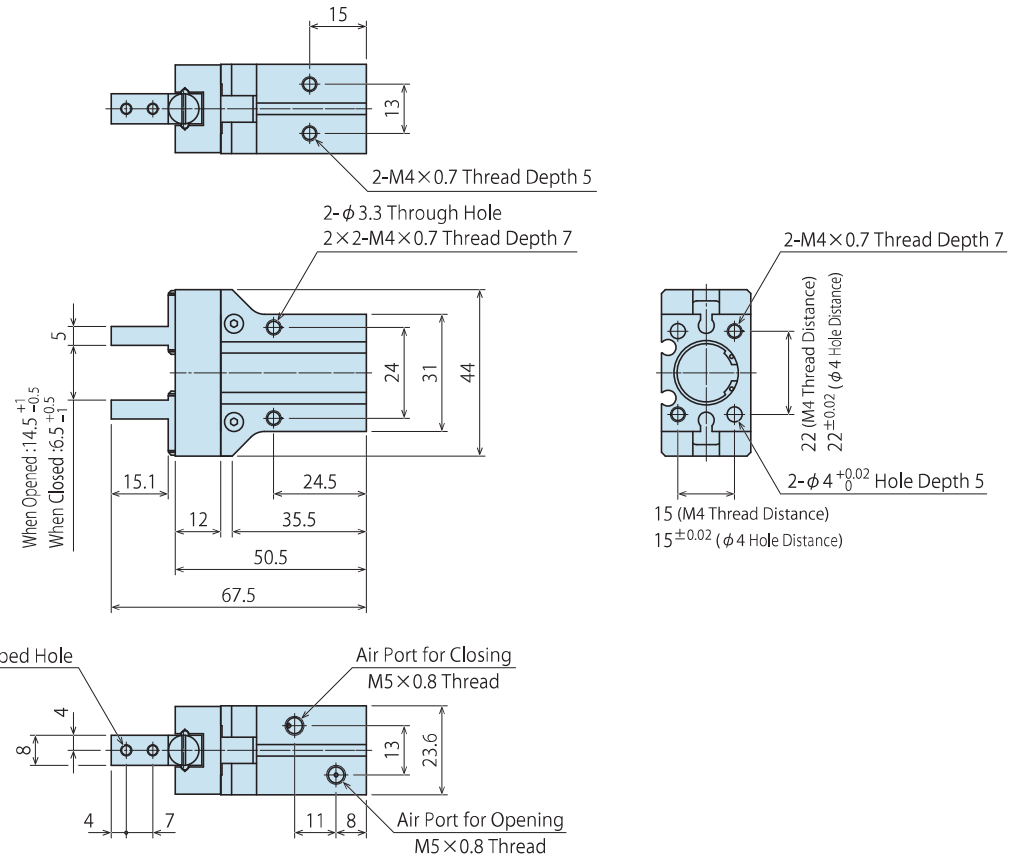

External Dimensions : WPA0200

※ The drawing shows the opened state of WPA0200.

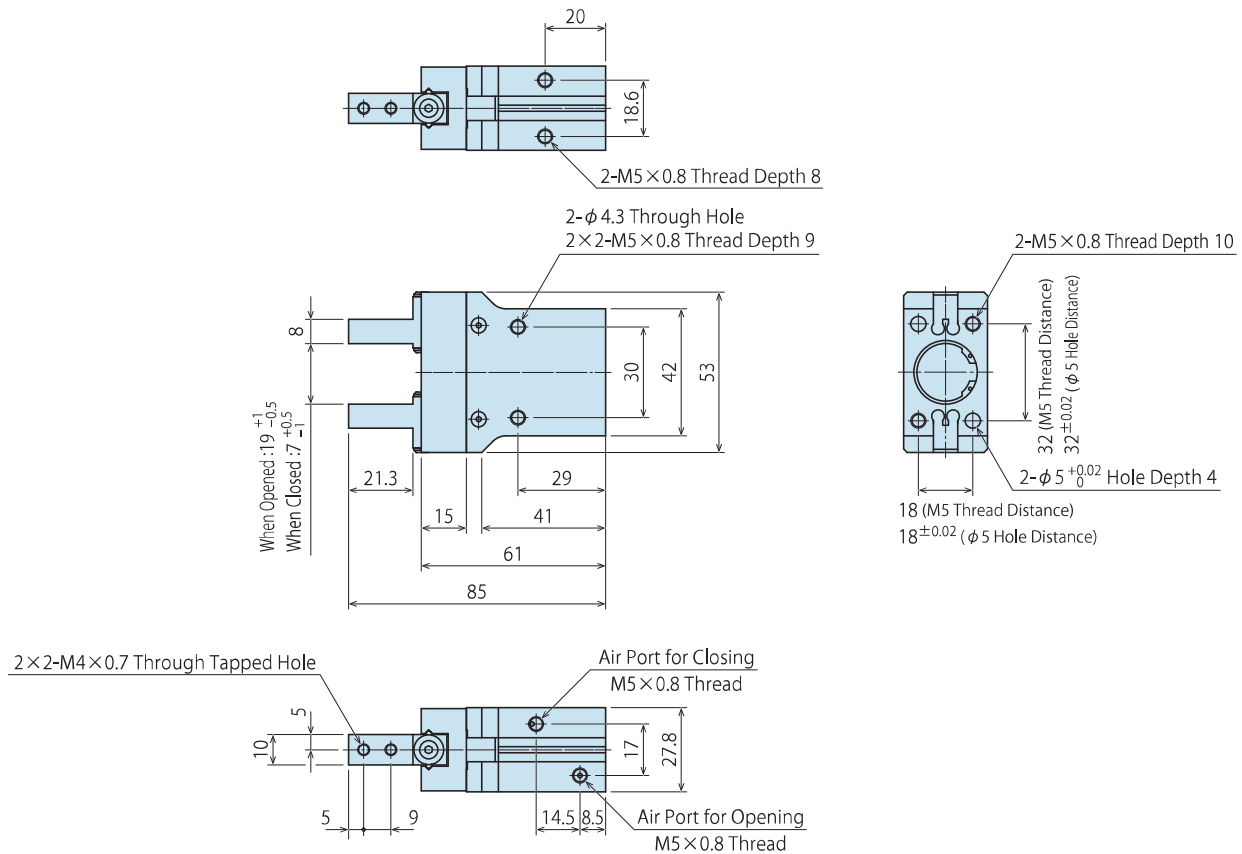

External Dimensions : WPA0250

※ The drawing shows the opened state of WPA0250.

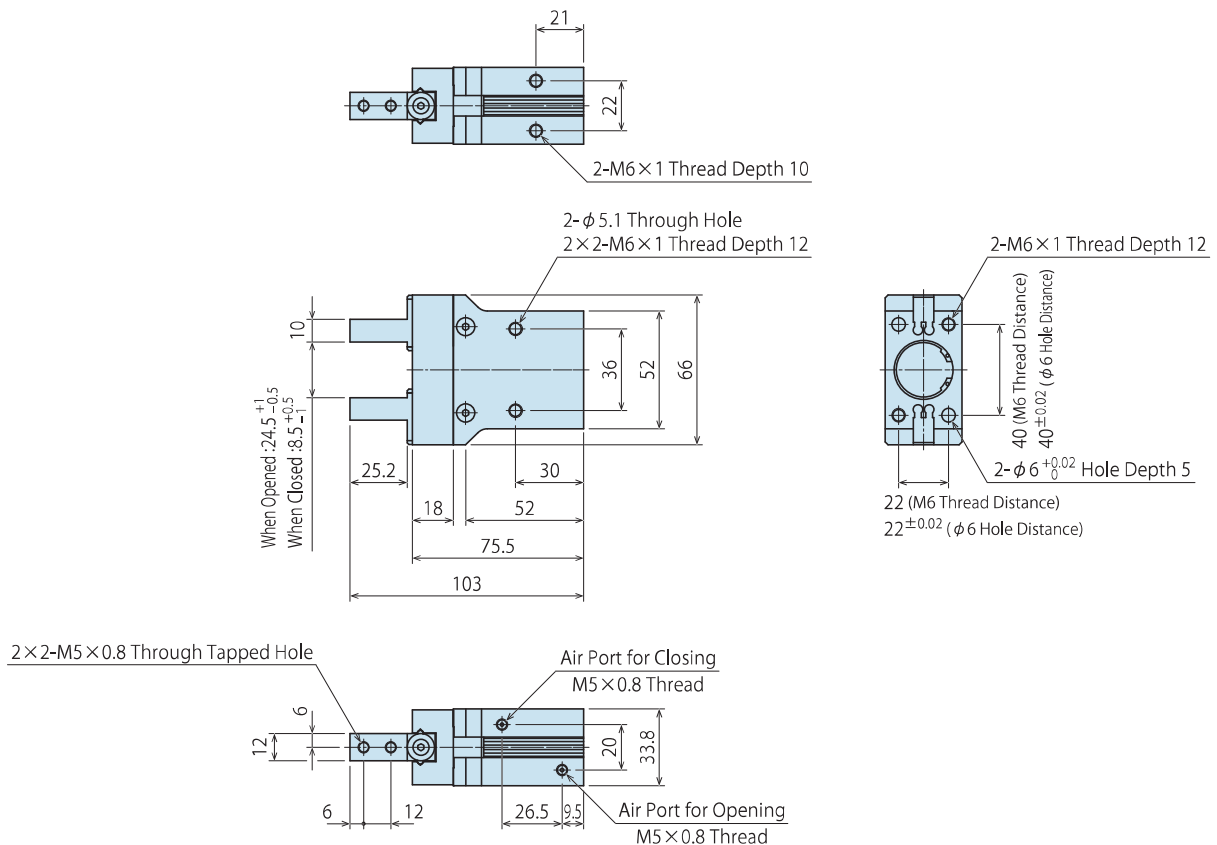
Locating
+
Clamp

Locating

Hand • Clamp

Support

Valve • Coupler

Cautions • Others

Pallet Gripper

WVA

Locating
Pin Clamp

SWP

High-Power
Pull Stud Clamp

WPT

JES

FA Pneumatic
Hole Clamp

WKH

Lifting
Hole Clamp

SWJ

Ball Lock
Cylinder

WKA

Pneumatic
Robotic Hands

WPW-C

WPS-C

WPA

WPH

WPP

WPQ

Auto Switch
Proximity Switch

JEP

High-Power Pneumatic
Hole Clamp

SWE

High-Power Pneumatic
Swing Clamp

WHE

High-Power Pneumatic
Link Clamp

WCE

Pneumatic
Hole Clamp

SWA

Pneumatic
Swing Clamp

WHA

Double Piston
Pneumatic
Swing Clamp

WHD

Pneumatic
Link Clamp

WCA

Air Flow
Control Valve

BZW

Manifold
Block

WHZ-MD

● External Dimensions : Auto Switch Installation Image (Reference)

※ This drawing shows the installation image of Auto Switch JEP0000-A2□ and JEP0000-B2□.
 Installation image of L-Shaped Auto Switch -A2V□ and -B3□ is different from this.
 Adjust installation position depending on the stroke position.

● For WPA0120

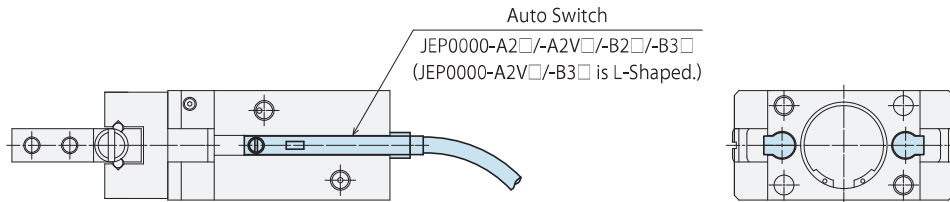

● For WPA0160

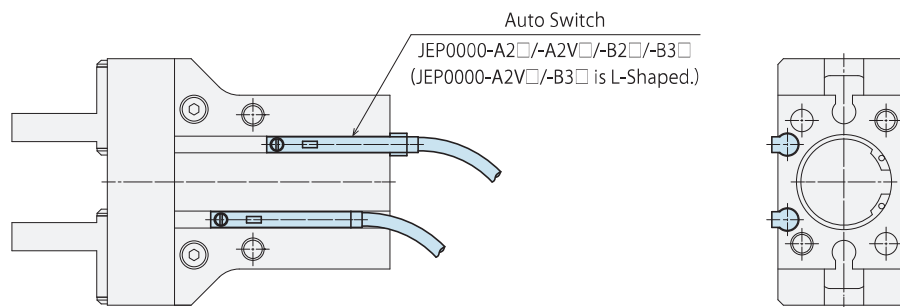

● For WPA0200

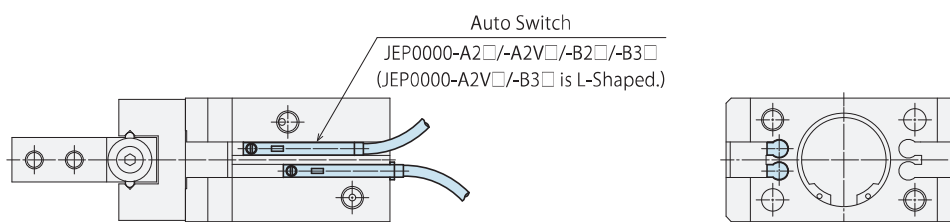

● For WPA0250

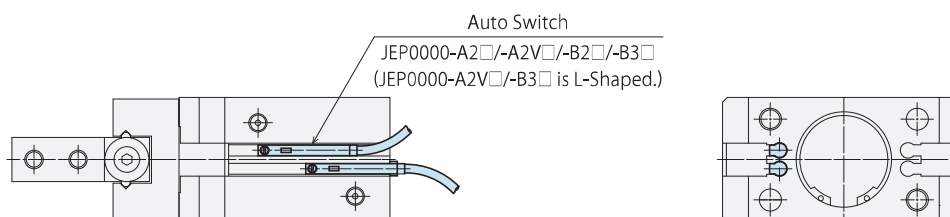

● Installation Method

● Tightening Torque for Cylinder Body

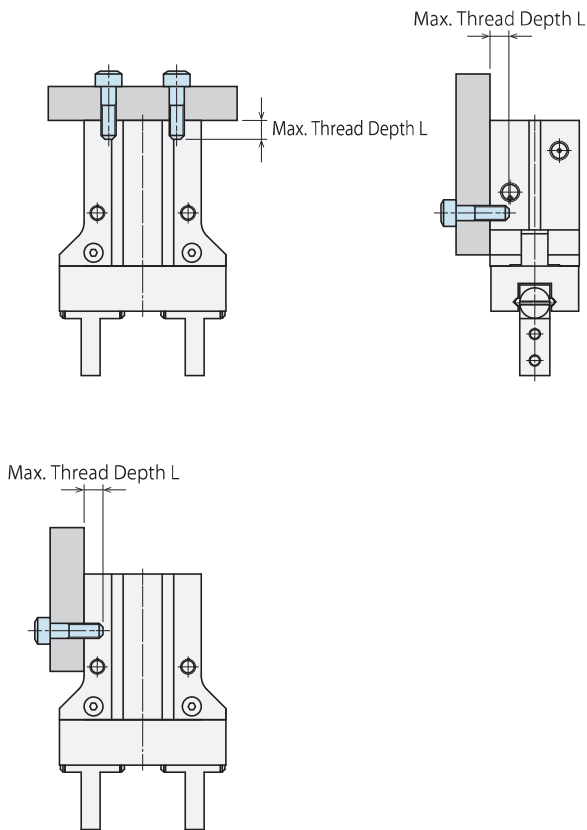

Model No.	Thread Size	Tightening Torque (N · m)	Max. Thread Depth L (mm)
WPA0120	M3×0.5	1.1	5
WPA0160	M4×0.7	2.5	5
WPA0200	M5×0.8	5.0	8
WPA0250	M6×1	7.9	10

● Tightening Torque for Gripper

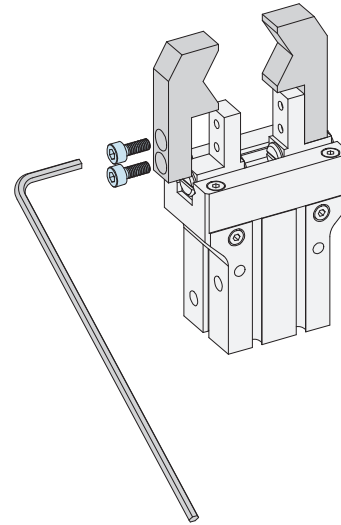

Model No.	Thread Size	Tightening Torque (N · m)	Max. Thread Depth L (mm)
WPA0120	M2.5×0.45	0.5	4
WPA0160	M3×0.5	1.1	5
WPA0200	M4×0.7	2.5	8
WPA0250	M5×0.8	5.0	10

Locating
+
Clamp

Locating

Hand · Clamp

Support

Valve · Coupler

Cautions · Others

Pallet Gripper

WVA

Locating
Pin Clamp

SWP

High-Power
Pull Stud Clamp

WPT

JES

FA Pneumatic
Hole Clamp

WKH

Lifting
Hole Clamp

SWJ

Ball Lock
Cylinder

WKA

Pneumatic
Robotic Hands

WPW-C

WPS-C

WPA

WPH

WPP

WPK

Auto Switch
Proximity Switch

JEP

High-Power Pneumatic
Hole Clamp

SWE

High-Power Pneumatic
Swing Clamp

WHE

High-Power Pneumatic
Link Clamp

WCE

Pneumatic
Hole Clamp

SWA

Pneumatic
Swing Clamp

WHA

Double Piston
Pneumatic
Swing Clamp

WHD

Pneumatic
Link Clamp

WCA

Air Flow
Control Valve

BZW

Manifold
Block

WHZ-MD