



Mechanized Solutions



Basic Automation Solutions



Integrated Solutions



Robotic Solutions



Power Wave[®] AC/DC 1000[®] SD, MAXsa[™] and Cruiser[™] Submerged Arc Equipment Systems

Bigger Welds, Faster.[™]

www.lincolnelectric.com/subarc

LINCOLN[®]
ELECTRIC
THE WELDING EXPERTS[®]



About The Lincoln Electric Company

Lincoln Electric is the world's leading manufacturer of welding equipment and consumables. Our focus is helping companies make their welding operations more effective, more efficient, and more profitable. We are dedicated to two equally important goals: exceptional quality and exceptional service. Our field support team — with hundreds of field sales engineers and thousands of knowledgeable and responsive Lincoln distributors in countries all over the world — is the largest in the industry. Innovative thinking. For a quality, service-first attitude; innovative design, manufacturing, and packaging; and worldwide strength—Choose Lincoln.

Submerged Arc Welding Platforms

Lincoln's advanced submerged arc systems couple the industry's most advanced power source with mobile, hard automation or robotic feeding equipment to achieve new levels of welding performance and operational efficiency. Whether your application is bridge decking, pressure vessels, panel line, seamer, pipe mill integrator solutions or submerged arc robotic welding, the software-driven Power Wave® AC/DC 1000® SD and your choice of integrated feeding equipment can help your operations improve weld quality, reduce welding and operational costs and increase weld team productivity.

- Our advanced Waveform Control Technology® allows operators to set all AC and DC arc and PLC-based fixture motion control parameters from a single mountable or hand-held extended-range pendant. It is no longer necessary to reverse electrode and work cables.
- With input current requirements reduced by up to 50% for our new inverter-based system, customers consistently report significant energy savings over traditional submerged arc welding equipment.
- Modular Power Wave® and MAXsa™ controller and feed head components are engineered to readily adapt the system for use in almost any indoor or outdoor heavy wall thickness submerged arc welding application.
- Power source, controller and feed heads are reliability tested to meet IP23 standards. Each is designed to withstand harsh environments and outdoor storage.

Lincoln Electric technical teams are standing by to assist you with set up, customized welding mode development optimized for your application, and welding consumables testing and selection.



Power Source

Power Wave® AC/DC 1000® SD 4-5



Mechanized Solution

Power Wave® AC/DC 1000® SD
Cruiser™ Tractor 6-7



Basic Automation Solution

Power Wave® AC/DC 1000® SD
MAXsa™ 10
Controller 8-9
MAXsa™ 22
Feed Head 10-11



Integrated Solution and Robotic Solution

Power Wave® AC/DC 1000® SD
MAXsa™ 19 Controller
and MAXsa™ 29 Feed Head 12-14

Appendix 15-23

Power Wave® AC/DC 1000® SD

Increase Productivity, Quality and Flexibility

The Power Wave® AC/DC 1000® SD delivers Waveform Control Technology® to submerged arc welding. Choose constant current or constant voltage operation and set variable frequency and amplitude. Software-driven AC, DC positive or DC negative output allows the user to control the deposition rate and penetration. The result over conventional power sources is increased weld speeds, consistently higher quality welds and improved efficiencies in a single or multi-arc environment.

Processes

- DC+ Submerged Arc
- DC- Submerged Arc
- Balanced AC Submerged Arc
- Variable AC Submerged Arc



Output



Input



Key Features

- **380 - 575 VAC, 50/60Hz Voltage Input** – Offers the ability to be connected anywhere in the world.
- **Voltage Compensation and Reliable Input Voltage Connection** – Provides consistent operation over $\pm 10\%$ input voltage variation.
- **No Hardware Reconfiguration Required with Easy Polarity Switching** – Eliminates downtime.
- **Easy to Parallel Machines or Run Multiple Arcs.**
- **3-Phase Voltage Input** – Eliminates the imbalance associated with transformer-based AC welding machines.
- **95% Power Factor Correction** – Enables connection of multiple machines on the same plant infrastructure for lower installation costs.
- **Severe Duty** – Can be stored outdoors. IP23 Rated.
- **ArcLink®, Ethernet, and DeviceNet™ Communication** – Offers remote process monitoring, control and troubleshooting.
- **True Energy™** – Measures, calculates and displays instantaneous energy in the weld for critical heat input calculations.
- **Production Monitoring™ 2** – Track equipment usage, store weld data and configure limits to assist in welding efficiency analysis.
- **Software Based Controls** – Can be upgraded as new features become available.
- **iARC™ Digital Control** - 90 times faster than the previous generation, delivering a responsive arc.
- **Each Unit is** – Factory burn-in tested at maximum output for 2 hours to ensure quality and reliability.

Technical Specifications

Product Name	Product Number	Input Voltage	Rated Output Current/Voltage/Duty Cycle	Input Current @ Rated Output	Output Range	Dimensions H x W x D in. (mm)	Net Weight lbs. (kg)
Power Wave® AC/DC 1000® SD	K2803-1 ⁽¹⁾	380/400/460/500/575/3/50/60	1000A/44V/100%	82/79/69/62/55	100-1000A	49.2 x 19.2 x 46.2 (1250 x 488 x 1174)	800 (363)

⁽¹⁾ Filter is required to meet CE conducted emission requirements. The K2444-3 must be used with the K2803-1.

KEY CONTROLS

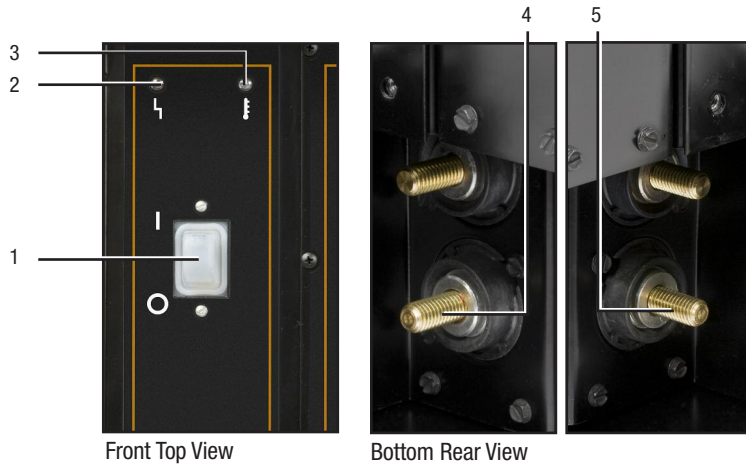

- 6. I/O Connectors for Synchronizing Machines
- 7. Work Sense Lead Connector
- 8. Ethernet Connector
- 9. Auxiliary Power Circuit Breaker
- 10. 10 Amp Wire Feeder Circuit Breaker
- 11. Auxiliary Output (115V, 10A AC)
- 12. Input Cable Location
- 13. DeviceNET™ Connector
- 14. Controller ArcLink® Connector
- 15. I/O Connectors for Paralleling Machines

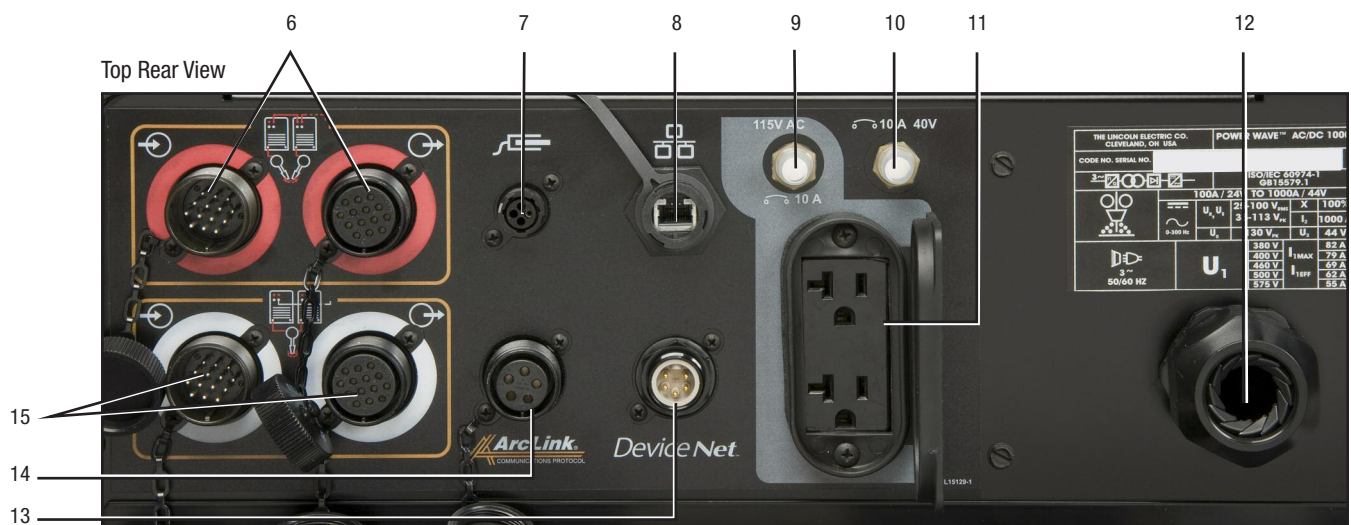

FEATURE LOADED, RUGGED CONSTRUCTION AND EASY MAINTENANCE

1. Easy Maintenance designed for Extreme Environments

- Pull-out back panel provides fast access to heat sinks and other components
- Re-Usable filter prevents particulate matter from entering the machine.

2. Production Monitoring™ 2

- Web-based Production Monitoring™ 2 allows fabricators to analyze and improve their welding operations and processes.

3. Easy-access Reconnect Panel

- Connect the Power Wave® AC/DC 1000® SD to an electrical connection almost anywhere in the world (380 up to 575 Volt input power).

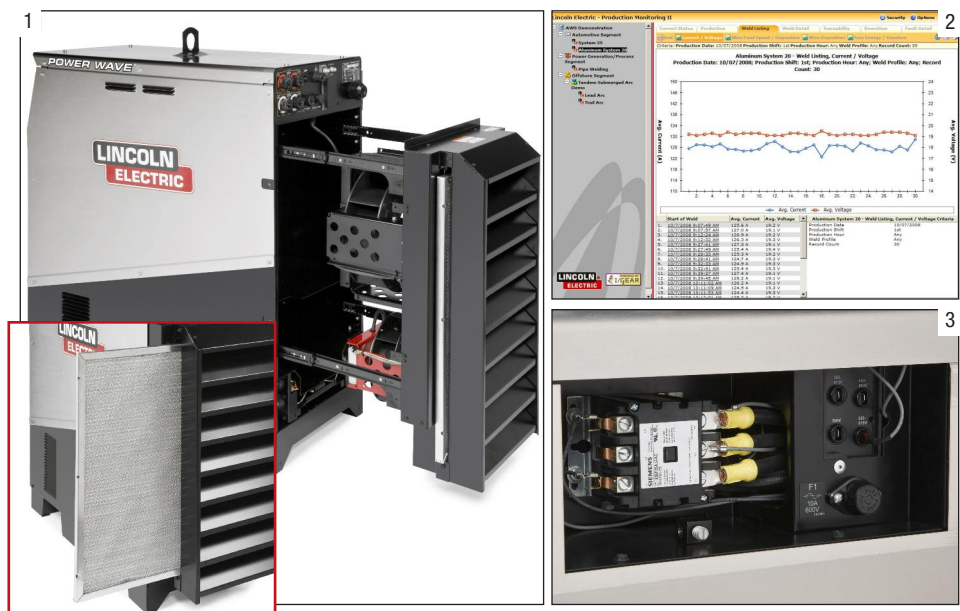

Cruiser™ Tractor

For The Long Haul

The Cruiser™ is a flexible wire feeding tractor for heavy plate submerged arc welding in field and yard applications. Designed for big joints on big jobs. Weld butt joints and fillet joints at deposition rates up to 30 lbs./hr. Comes ready to weld with joint tracking kits and drive rolls for 5/32 in. (4.0 mm) solid wire.

Processes
Submerged Arc

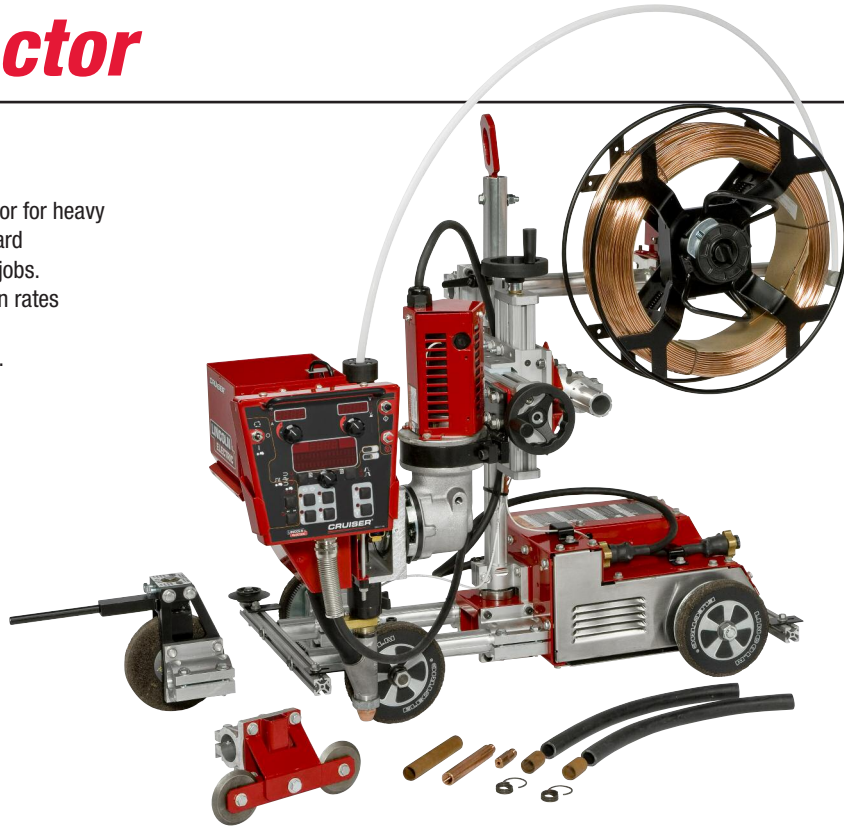

Output



Input



Key Features

- **Designed for Welding Big Joints on Big Jobs** – Ideal for welding heavy plate on barges, ships, large tanks, bridges, and offshore platforms.
- **High Deposition Rates Up to 30 lbs./hr.** – Rated output of 1000 amps at 100% duty cycle.
- **Versatile Travel Capabilities** – 3 or 4 wheel configuration for use with or without track.
- **Lightweight Pendant Control with Digital Meters** – Save procedures, apply procedure limits, and lockout any or all controls.
- **Rugged Mast and Arm** – Keeps the wire drive in a steady position and allows flexible adjustment.
- **Proven Industrial Wire Drive Design** – Rotates on two axes and is attached to heavy duty cross slides for any torch angle. Feed up to 7/32 in. (5.6 mm) diameter wire.

K2607-1 Includes

- Pendant Control
- Butt, Fillet and Lap Joint Tracker
- 50-60 Lb. (22.7 - 27.2 kg) Coil Adapter
- Wire Straightener
- Drive Roll/Guide Tube Kit for 5/32 in. (4.0 mm) solid wire
- Contact Nozzle Assembly
- Nozzle Extension
- Contact Tip for 5/32 in. (4.0 mm) solid wire

Technical Specifications

Product Name	Product Number	Input Power	Rated Output Current/ Duty Cycle	Travel Speed in/min (m/min)	Gearing	Wire Feed Speed Range ipm (m/min)	Wire Size Range in. (mm) Solid	Dimensions H x W x D in. (mm)	Net Weight lbs. (kg)
Cruiser™ Tractor	K2607-1	40 VDC	1000A / 100%	10 - 100 (0.25 - 2.5)	142:1	15 - 200 (0.4 - 5.0)	1/16 - 7/32 (1.6 - 5.6)	29 x 23 x 36 (737 x 584 x 914)	140 (63.5)

KEY CONTROLS



1. Digital Meters

2. Travel Mode Switch

- Auto
- Off
- Manual

3. Pushbutton Menu Options

- Weld Mode Select
- Frequency and Balance
- Travel Options

4. Travel Direction:

- Forward
- Reverse

5. Jog

6. Start and Stop Pushbutton

7. Arc Start/End Options Selector

- Start Options Indicator Light
- End Options Indicator Light

8. Feed Reverse/Feed Forward Buttons

9. 4 Memory Buttons:

- Save common procedures. (including travel)
- Apply operator range or limits
- Lockout changes for procedure control

RUGGED DESIGN & FLEXIBLE ADJUSTMENT FOR ANY CONFIGURATION

1. Mast and Frame

- Heat treated aluminum alloy tubing
- Creates a rigid frame for steady position
- Mast and boom completely separates from the base for mobility

2. Heavy Duty Cross Slides

- Easy adjustment of electrode stick-out and position
- Accurate positioning of the electrode in joint

3. Hardened Base Construction

- Stainless steel to reduce corrosion
- Heat shield to withstand preheated plate
- Environmentally hardened (IP23 Rated)

4. Stable Travel and Tracking

- 3 or 4 wheel configuration on same model
- Easy to use clutch
- Factory ready for use with or without track
- Patent Pending wheel design that endures impacts, is high temperature resistant and excellent traction

5. Proven Industrial Wire Drive

- Feeds wire up to 7/32 in. (5.6 mm) diameter
- Changeable gears for a wide range of wire feed speed range
- Rotation in two directions for any torch angle
- 1000A, 100% Duty Cycle

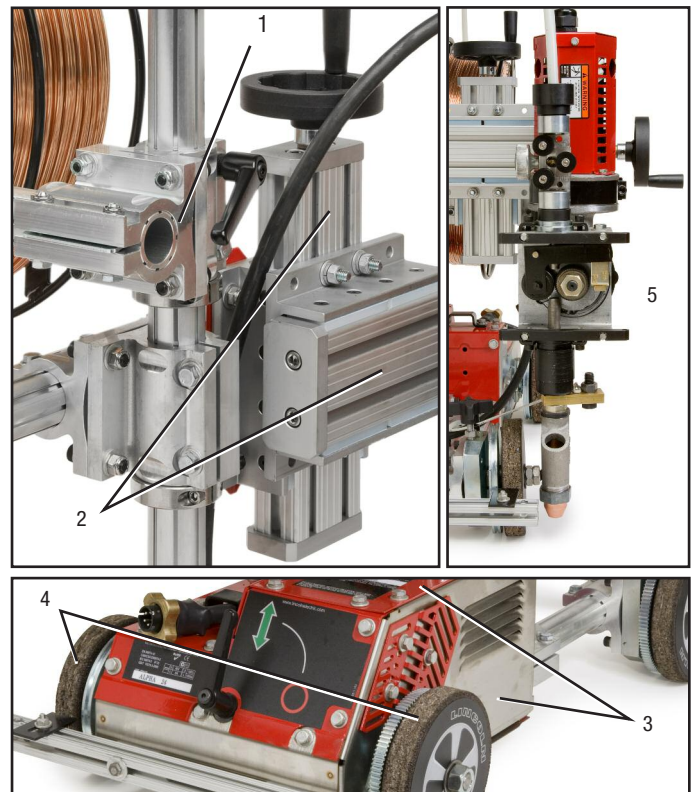

MAXsa™ 10 Controller

ArcLink®-enabled Controller for Power Wave® AC/DC 1000® SD Systems

The MAXsa™ 10 controller offers a single monitoring and control point for the entire hard automation welding system. Operators have full control over AC and DC welding parameters and easy PLC interfacing to control fixture travel, timers and other system commands.

Processes
Submerged Arc



Output



Input



Key Features

- **Severe Duty Ready** – The controller is IP23 rated and ready for operation in harsh environments.
- **Pendant Box** – Mount the controller in the standard protective box or remove the pendant for hand-held operation. Extend hand-held operation from 4 feet (1.2 m) up to 100 feet (30.5 m) with an ArcLink® extension cable.
- **Eight Procedure Memories** – Pre-set and save your optimal welding parameters for repeating applications and recall later for fast changeovers.
- **User-Friendly Controls** – Clear digital display and controls make it easy to set weld modes, AC operation, strike/start/end options, travel stop/start, timers and other parameters.
- **Limit Control** – Apply operator procedure limits or lockout on any or all parameters.
- **Waveform Control Technology®** – Allows the user to choose from a library of pre-programmed weld modes. Parameters for each mode can be adjusted within a limited range to achieve optimal balance between deposition rate and penetration.

Technical Specifications

Product Name	Product Number	Input Power ⁽¹⁾	Dimensions H x W x D in. (mm)	Net Weight lbs. (kg)
MAXsa™ 10 Controller	K2814-1	40 VDC	15 x 13 x 4 (381 x 259 x 102)	25 (11.3)

⁽¹⁾ When not driving a motor.

KEY CONTROLS

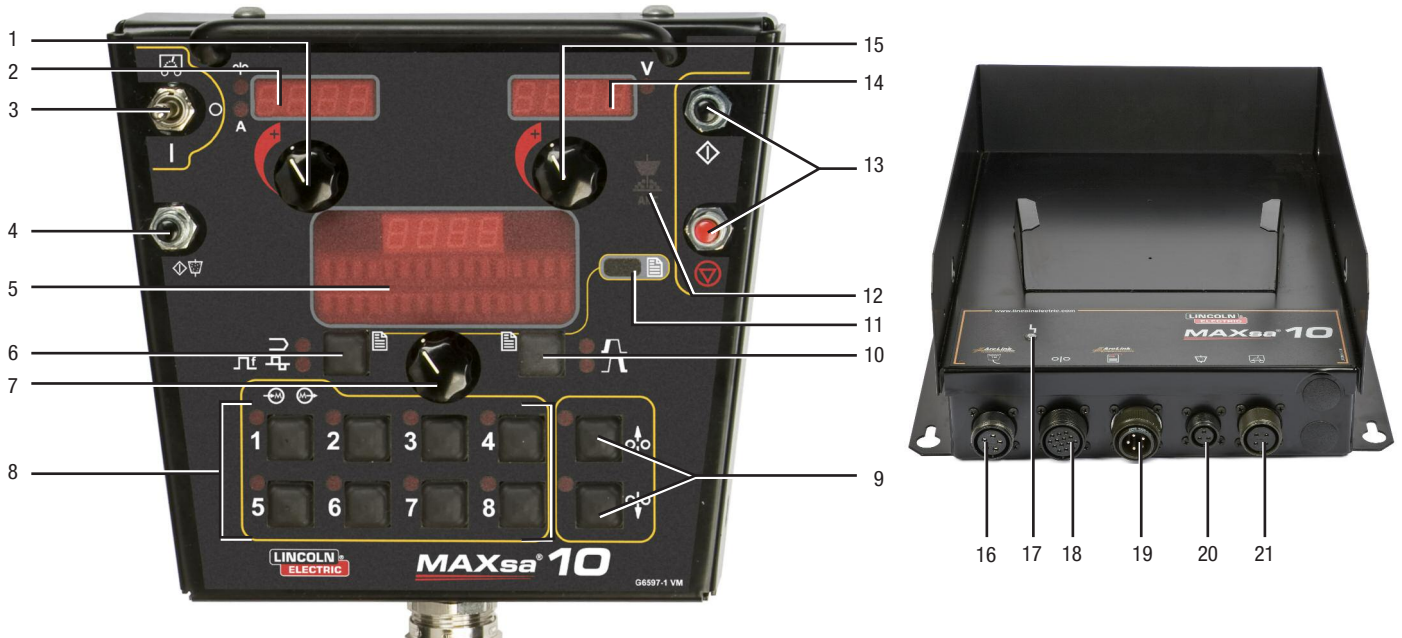

- 1. AMPS/WFS Control**
- 2. AMPS/WFS Display**
 - AMPS Indicator Light
 - WFS Indicator Light
- 3. Travel Switch**
 - Auto/Off/Manual
- 4. Flux Hopper Switch**
- 5. Mode Select Panel (MSP) Display**

- 6. Weld Mode Selector**
 - Weld Mode Indicator Light
 - Frequency/Balance Indicator Light
- 7. Mode Select Panel Control Knob**
- 8. Eight Memory Buttons:**
 - Save common procedures
 - Apply operator range or limits
 - Lockout changes for procedure control
- 9. Feed Reverse/Feed Forward Buttons**

- 10. Arc Start/End Options Selector**
 - Start Options Indicator Light
 - End Options Indicator Light
- 11. Set-Up Menu Indicator**
- 12. Arc Established Indicator**
- 13. Stop/Start Buttons**
- 14. Volts Display**
 - Volts Indicator Light
- 15. Volts Control**

- 16. User Interface/Pendant Connector**
- 17. Status LED**
- 18. Wire Drive Connector**
- 19. Power Source Connector**
- 20. Flux Hopper Connector**
- 21. Travel Carriage Connector**

RUGGED DESIGN, FLEXIBLE CONNECTION

- 1. IP23 Rated** – Tested and approved to withstand rain, humidity, dust and other environmental conditions. When placed vertically, the unit can be stored outdoors.
- 2. Hard Automation Connection** – Motion control, limit switches, PLC inputs and other auxiliary equipment are easily added to control device starting, stopping and other functions.
- 3. Hand-held Options** – The protective base unit shell facilitates fixed mounting and protects the controller. To get closer to the work, detach the controller for hand-held operation.



MAXsa™ 22 Feed Head

Submerged Arc Hard Automation Wire Drive

Designed specifically for hard automation applications, the MAXsa™ 22 Wire Drive delivers accurate wire feeding of large diameter submerged arc wires. Based on Lincoln's proven gearbox and cast aluminum feedplate, the MAXsa™ 22 model features a 32VDC permanent magnet, high torque motor that delivers plenty of traction to push up to 7/32 in. (5.6 mm) diameter solid wire. A top speed of up to 500 ipm (11.43 m/min) can be achieved by changing the gear ratio.



Output



Input



Processes
Submerged Arc



Key Features

- **Flexible Configuration** – Can be used in single, tandem, Twinarc® or multiple arc applications.
- **Closed Loop Speed Control** – Facilitates full control over starting, running and stopping wire feed speed.
- **IP23 Rated** – Tested to withstand harsh environments.
- **Standard Conversion Kits** – Used to change the speed ratio to match the requirements of your application.
- **Multi-Axis Rotation** – Rotational feed head adjustment in two planes allows flexible, accurate setup for fixturing or arc locating. Additional positioning flexibility can be achieved with optional horizontal and vertical lift adjusters.
- **Standard Accessories** – Including an adjustable wire straightener, cross-seam adjuster and electrical valve flux hopper and mounting bracket for TC-3 carriage.

Technical Specifications

Product Name	Product Number	Input Power	Rated Output Current / Duty Cycle	Gear Box	Wire Feed Speed Range ⁽¹⁾ ipm (m/min)	Wire Size Range ⁽¹⁾ in. (mm) Solid	Dimensions H x W x D in. (mm)	Net Weight lbs. (kg)
MAXsa™ 22 Head (includes flux hopper)	K2370-2	40 VDC	1000A/100%	142:1 ⁽¹⁾	10 - 200 (.25 - 5.08)	5/32 - 7/32 (4.0 - 5.6)	23.5 x 17 x 20 (597 x 432 x 508)	80 (36.3)
				95:1 ⁽¹⁾	10 - 300 (.25 - 7.62)	1/8 - 5/32 (3.2 - 4.0)		
				57:1 ⁽¹⁾	40 - 500 (1-12.7)	.045 - 1/16 (1.1 - 1.6)		

⁽¹⁾ 142:1 gear box is standard. Conversion Kit supplied for conversion to 95:1 with Wire Drive (K2370-2, K2312-2, or K2311-1)

A CLOSER LOOK

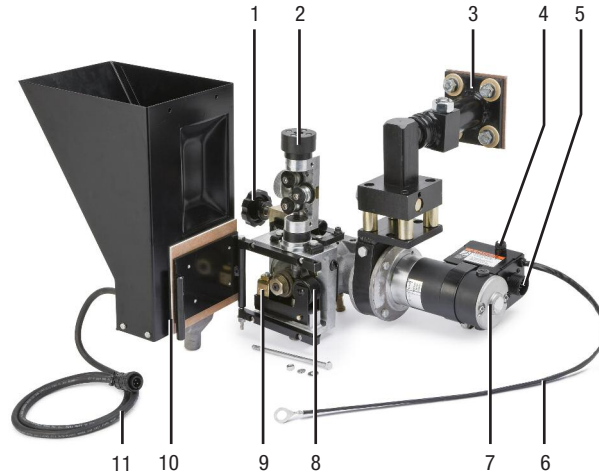

- 1. Cross Seam Adjuster
- 2. Wire Straightener
- 3. Mounting Bracket
- 4. Fuse
- 5. 14-Pin Connector
- 6. Lead (67)
- 7. Motor
- 8. Idle Roll Arm
- 9. Tension Indicator
- 10. Flux Hopper
- 11. Flux Valve Connector

OPTIONAL TC-3 TRACTOR

TC-3 Tractor

The TC-3 travel carriage allows the mounting of up to two feed heads/controllers and wire reels to a beam for basic hard automation installations.



Beam Profile

Recommended for the TC-3 carriage. (See manual for more precise dimensions.)

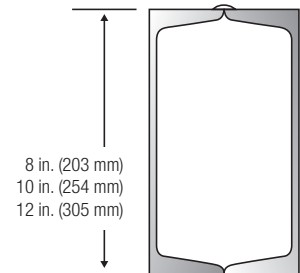

CONTACT NOZZLES (ONE REQUIRED)

1. Submerged Arc Contact Nozzle Assembly

For 5/64 thru 3/16 in. (2.0 thru 4.8 mm) electrode at currents generally below 600 amps. Outer flux cone gives full flux coverage with minimum consumption. (Rated for up to 650 amps.)

2. Positive Contact Assembly

For single arc welding at high currents.

3. Contact Jaw Assembly

Single arc contact jaw assembly for 1/8 - 7/32 in. (3.2 - 5.6 mm) diameter wire. Maximum life at currents over 600 amps.

4. ESO (Extended Stick-Out) Extension

Linc-Fill long stickout extension for K148A Single Arc Positive Contact Nozzle Assembly. Required for long stickout technique.

5. Narrow Gap Deep Groove Nozzle

For single arc 3/32 in. (2.4 mm) diameter wire welding on thick walled steel plate with nearly parallel-sided, narrow gap joint preparations.

6. Large Wire Twinarc® Contact Assemblies

Feeds two 5/64 in. (2.0 mm), 3/32 in. (2.4 mm) or 1/8 in. (3.2 mm) wires for submerged arc welding on "Fast-Fill" joints or hardfacing beads.

7. Tiny Twinarc® Contact Assemblies

Feeds two electrodes for high speed submerged arc welds. Includes contact nozzle, wire guides, drive rolls and guides, and a second wire reel and mounting bracket.

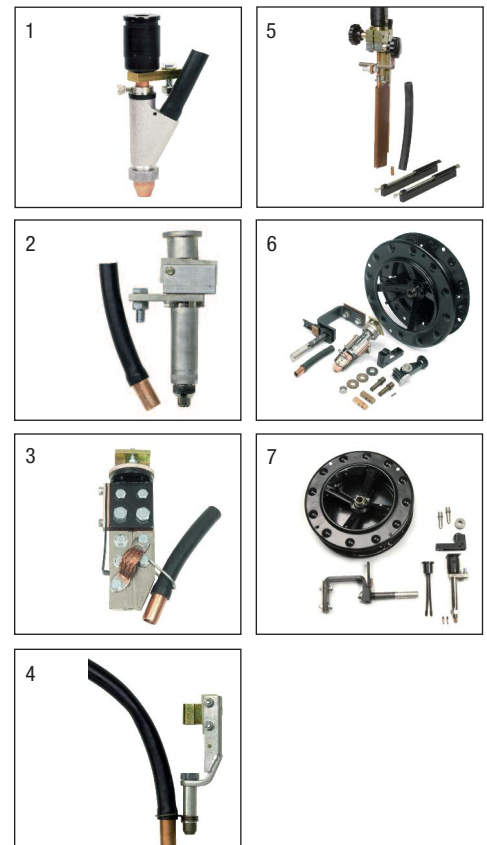

MAXsa™ 19 Controller and MAXsa™ 29 Feed Head

Submerged Arc Systems for Fabrication Integrators and Robotic Applications

The MAXsa™ 19 controller is specifically designed to relay wire feed commands to the MAXsa™ 29 when a customer-supplied user interface is used in place of the MAXsa™ 10 controller. Typically, this occurs in a variety of third party fabrication integrator solutions that include integration hardware like turning rolls, panel lines, seamers and pipe mills fixturing.

The compact MAXsa™ 29 Feed Head is intended for integrator solutions as well as the latest submerged arc robotic applications.

Contact Lincoln Electric Automation Division via email at automation@lincolnelectric.com for more information on robotic applications.

Processes
Submerged Arc



Key Features

MAXsa™ 19 Controller

- Compact size is easy to position in custom integrator solutions.
- Fast digital communication with the Power Wave® AC/DC 1000® SD via Arclink® cable and to the wire drive via a 14 pin control cable.
- Standard I/O connector block for start/stop, forward/reverse feed and shutdown input interfacing with external accessories.
- Standard Status indicator aids diagnostic system troubleshooting.
- IP23 Rated – Tested to withstand harsh environments.

MAXsa™ 29 Feed Head

- Closed Loop Speed Control – Facilitates full control over starting, running and stopping wire feed speed.
- 32VDC permanent magnet, high torque motor that delivers plenty of traction to push up to 7/32 in. (5.6 mm) diameter solid wire. Top speed of up to 500 ipm (11.43 m/min) can be achieved by changing the gear ratio.
- IP23 Rated – Tested to withstand harsh environments.
- Standard conversion kits – Used to change the speed ratio to match the requirements of your application.
- Rotational feed head adjustment in one plane allows flexible, accurate setup for fixturing.
- Standard adjustable wire straightener.

Technical Specifications

Product Name	Product Number	Input Power ⁽¹⁾	Rated Output Current / Duty Cycle	Gear Box	Wire Feed Speed Range ⁽²⁾ imp (m/min)	Wire Size Range ⁽²⁾ in. (mm) Solid	Dimensions H x W x D in. (mm)	Net Weight lbs. (kg)
MAXsa™ 19 Controller	K2626-2	40 VDC	1000A / 100%	Not Applicable			9 x 10.5 x 3 (229 x 267 x 76)	7 (3.2)
MAXsa™ 29 Feed Head	K2312-2	40 VDC	1000A / 100%	142:1 ⁽¹⁾	10 - 200 (.25 - 5.08)	5/32 - 7/32 (4.0 - 5.6)	13 x 16 x 10 (330 x 406 x 254)	35 (15.9)
				95:1 ⁽¹⁾	10 - 300 (.25 - 7.62)	1/8 - 5/32 (3.2 - 4.0)		
				57:1 ⁽¹⁾	40 - 500 (1-12.7)	.045 - 1/16 (1.1 - 1.6)		

⁽¹⁾ When not driving a motor. ⁽²⁾ 142:1 gear box is standard. Conversion Kit supplied for conversion to 95:1 with Wire Drive (K2370-1, K2312-2, or K2311-1)

KEY CONTROLS

MAXsa™ 19 Controller



MAXsa™ 29 Feed Head

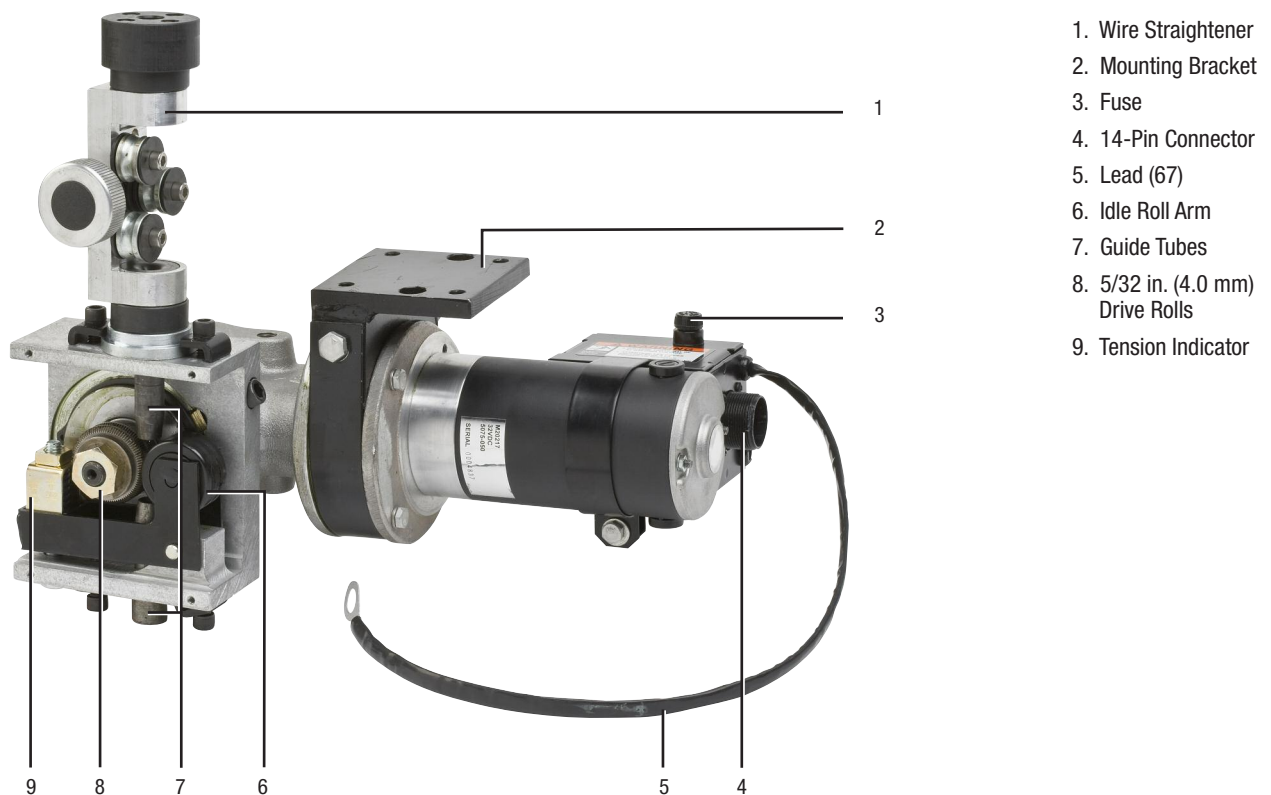

DIGITAL COMMUNICATIONS AND SEAMLESS INTEGRATION

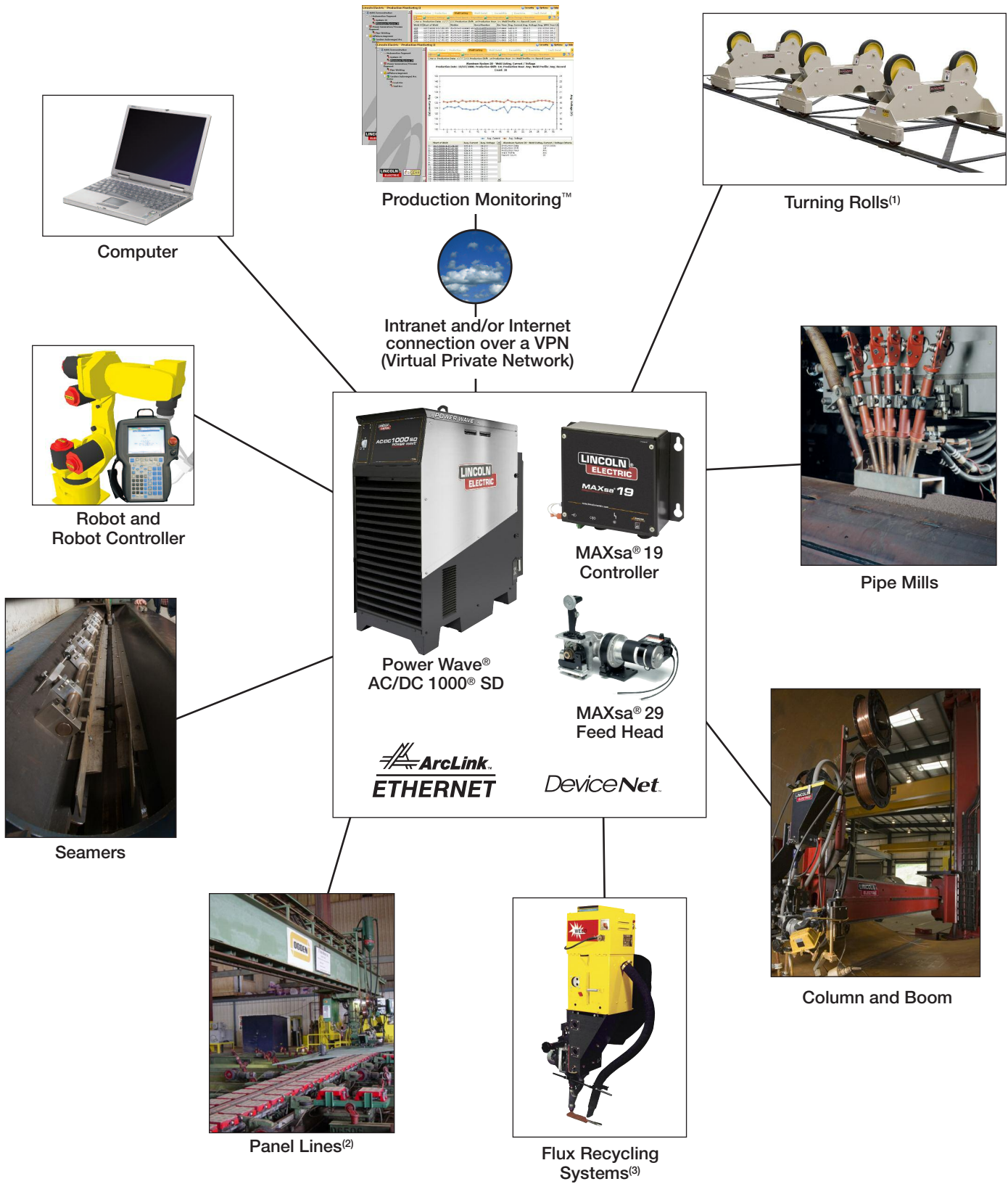

⁽¹⁾ Photo used with permission of Pandjiris, Inc. ⁽²⁾ Photo used with permission of Ogden Welding Systems, Inc. ⁽³⁾ Photo used with permission of Weld Engineering Co., Inc.

SINGLE ARC MOBILE CONFIGURATION

RECOMMENDED EQUIPMENT

Product Number	Product Description	Qty. Required
K2803-1	Power Wave® AC/DC 1000® SD	1
K2607-1	Cruiser™ Tractor	1
K2683-xx	Heavy Duty ArcLink® Control Cable	1
K1811-xx	Work Sense Lead	1

Connection Diagram - Cruiser™ Tractor System

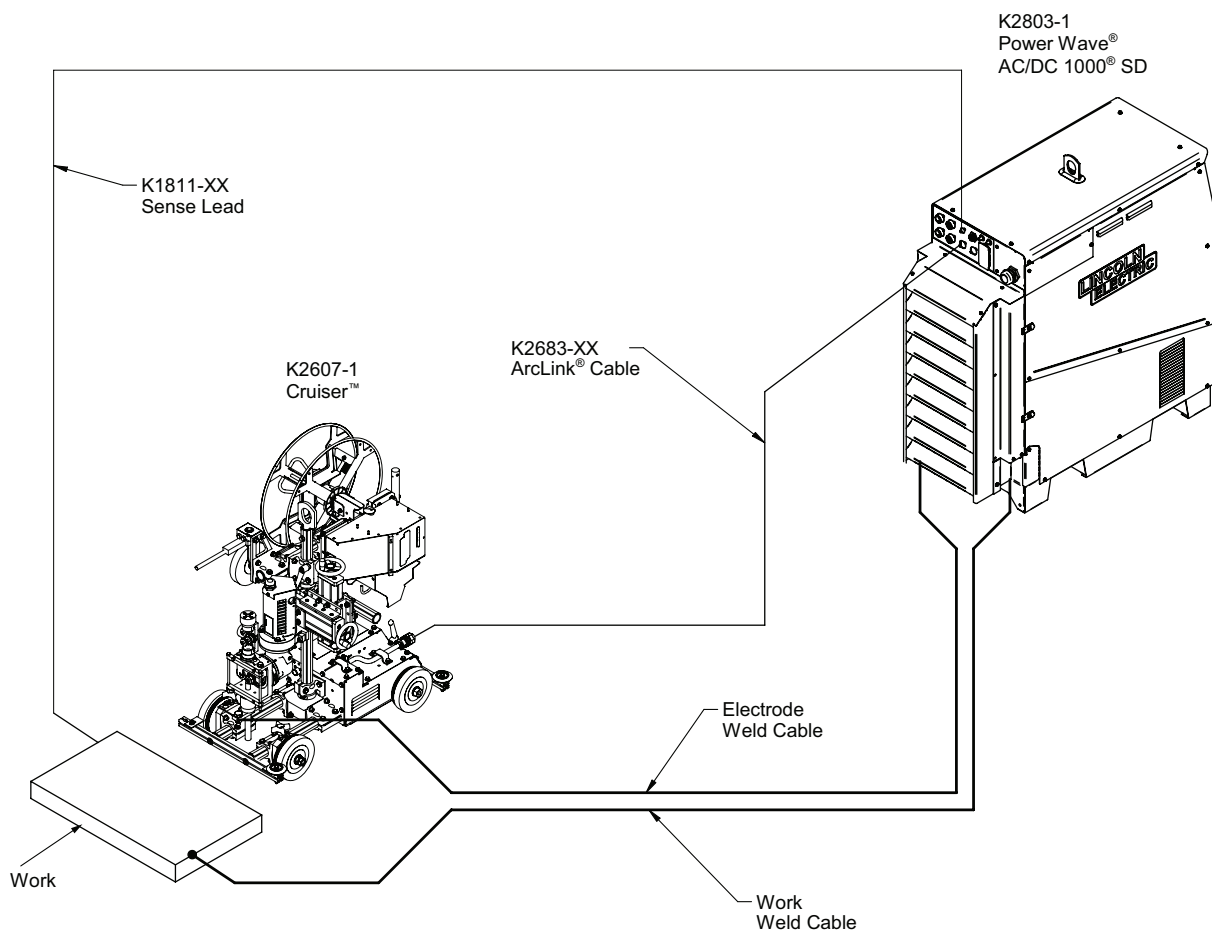

SINGLE ARC CONFIGURATION

RECOMMENDED EQUIPMENT

Product Number	Product Description	Qty. Required
K2803-1	Power Wave® AC/DC 1000® SD	1
K2814-1	MAXsa™ 10 Controller	1
K2370-2	MAXsa™ 22 Wire Drive	1
K231-1	Submerged Arc Contact Nozzle Assembly [3/32 in. (2.4 mm), 1/8 in. (3.2 mm), 5/32 in. (4.0 mm)]	1
K2683-XX	Heavy duty ArcLink® Control Cable	1
K1785-XX	14-pin Control Cable	1
K1811-XX	Work Sense lead	1

Contact Lincoln Electric Automation Division via email at automation@lincolnelectric.com for more information on robotic applications.

Connection Diagram - Single Arc System

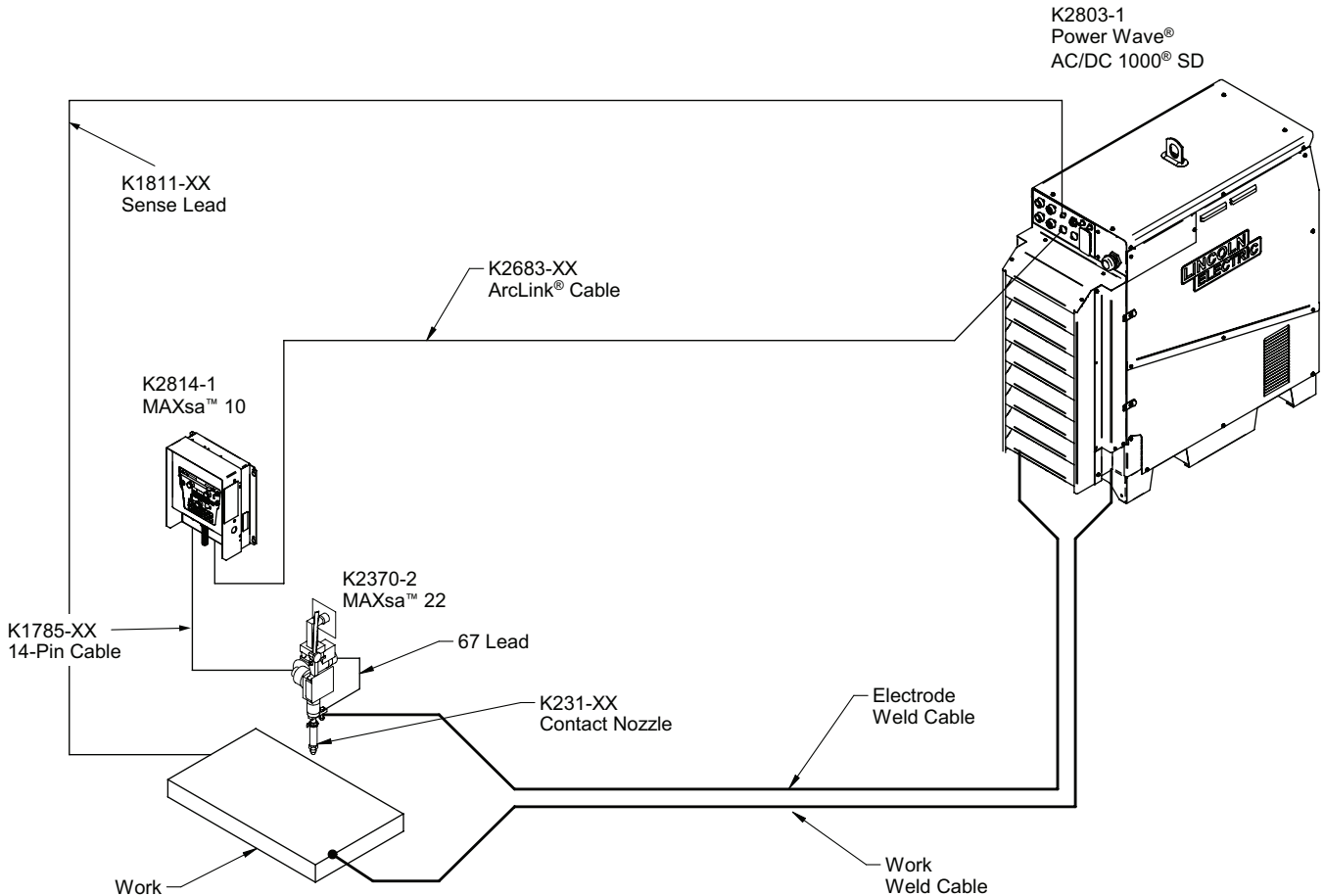

DUAL ARC CONFIGURATION (For paralleling or more than two arcs, please contact your local Lincoln Electric Office.)

RECOMMENDED EQUIPMENT

Product Number	Product Description	Qty. Required
K2803-1	Power Wave® AC/DC 1000® SD	2
K2814-1	MAXsa™ 10 Controller	2
K2370-2	MAXsa™ 22 Wire Drive	2
K231-1	Submerged Arc Contact Nozzle Assembly [3/32 in. (2.4 mm), 1/8 in. (3.2 mm), 5/32 in. (4.0 mm)]	2
K2683-XX	Heavy duty ArcLink® Control Cable	2
K1785-XX	14-pin Control Cable (controller to wire drive)	2
K1785-XX	14-pin Control Cable (machine to machine)	1
K1811-XX	Work Sense lead	1

Contact Lincoln Electric Automation Division via email at automation@lincolnelectric.com for more information on robotic applications.

Connection Diagram - Tandem Arc System

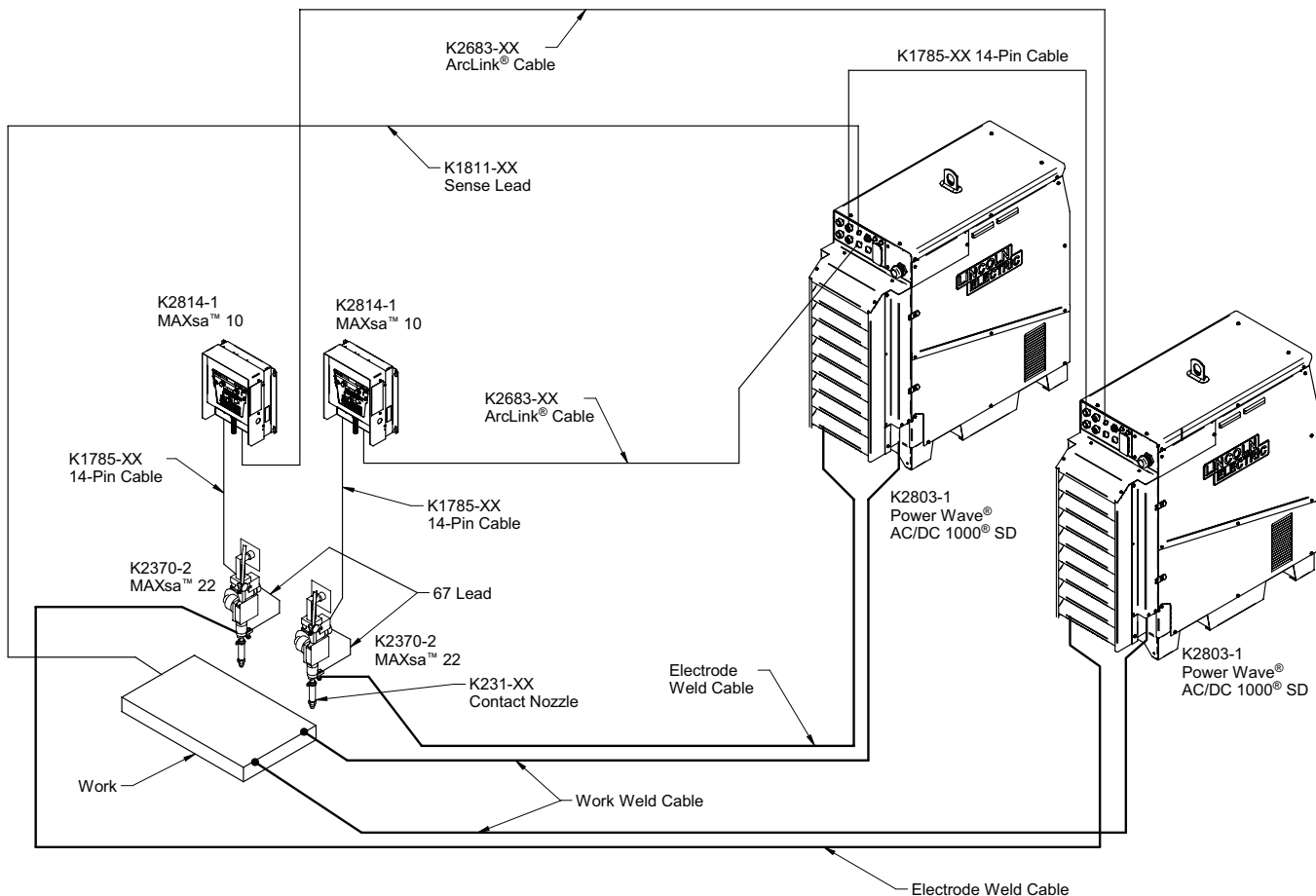

Mild Steel SAW Wire Feeding Capability

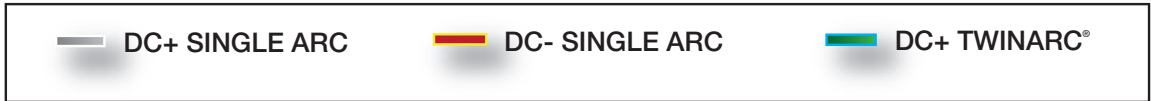
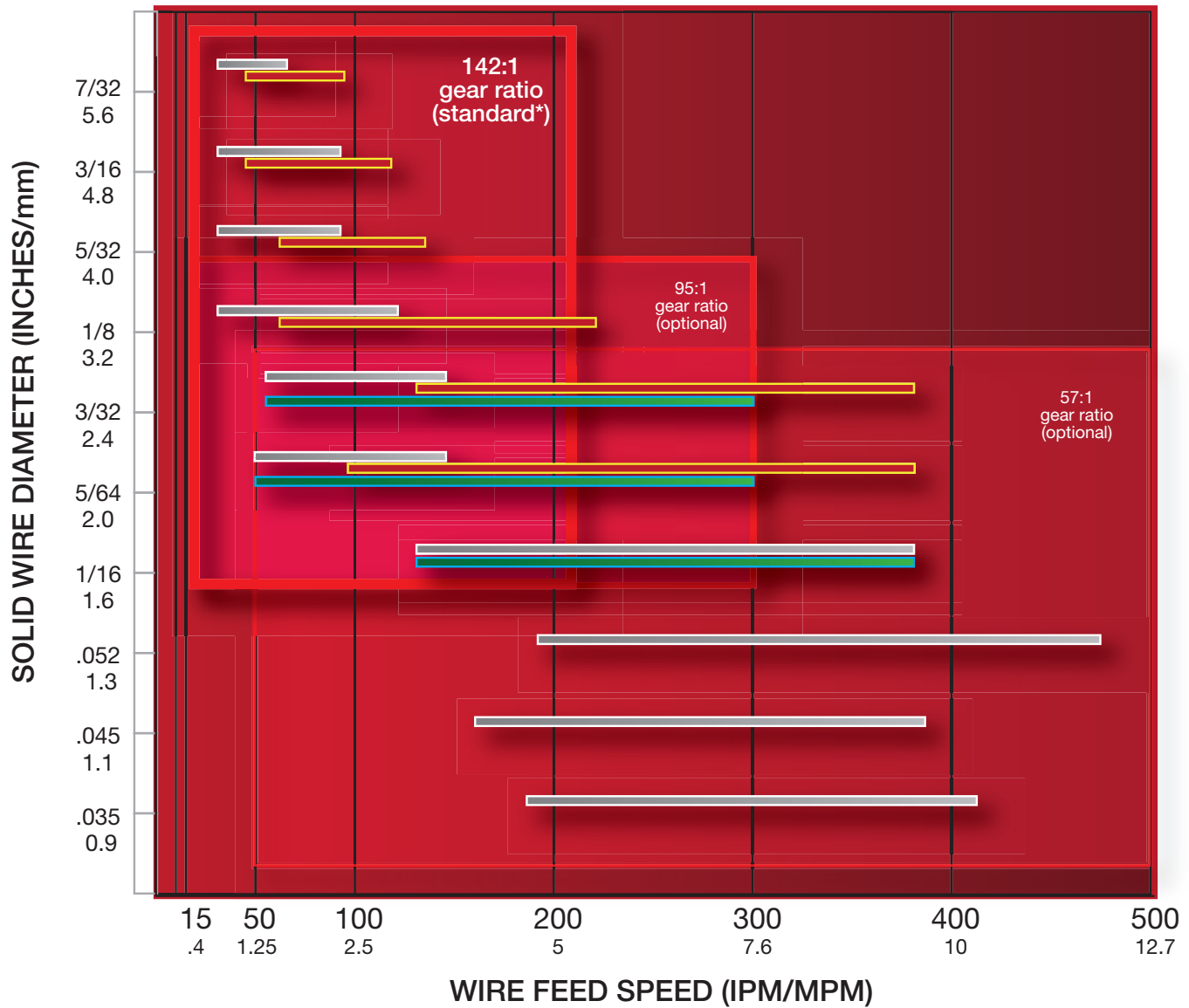

* On MAXsa™ Feed Heads

RECOMMENDED ACCESSORIES AND OPTIONS

14-PIN CONTROL CABLE (CANNOT BE EXTENDED)		
Length	Part No.	
12 ft. (3.7 m)	K1785-12	
16 ft. (4.9 m)	K1785-16	
25 ft. (7.6 m)	K1785-25	
50 ft. (15.2 m)	K1785-50	
100 ft. (30.5 m)	K1785-100	

5-PIN HEAVY DUTY ARCLINK® CONTROL CABLE [CAN BE EXTENDED UP TO 200 FT. (61 M) TOTAL LENGTH]			
	Length	Part No.	
Heavy Duty	25 ft. (7.6 m)	K2683-25	
	50 ft. (15.2 m)	K2683-50	
	100 ft. (30.5 m)	K2683-100	

SENSE LEAD KIT		
Length	Part No.	
50 ft. (15.2 m)	K1811-50	
75 ft. (23 m)	K1811-75	
100 ft. (30.5 m)	K1811-100	

WELD POWER CABLES		
	Part No.	Required
For Up to 250 ft. (75 m) @ 80% Duty Cycle		
35 ft. - 2x4/0	K2163-35	1
60 ft. - 2x4/0	K2163-60	1
110 ft. - 1x4/0	K2163-110	2
For Up to 250 ft. (75 m) @ 100% Duty Cycle		
10 ft. - 1x3/0	K1842-10	3
35 ft. - 1x3/0	K1842-35	3
60 ft. - 1x3/0	K1842-60	3

MAXsa™ DRIVE ROLL KIT INFORMATION		
Drive Roll Kit Number	Wire Sizes and Types	
KP1899-1	3/32 - 7/32 in. Wires	
KP1899-2	1/16 - 3/32 in. Wires	
KP1899-3	.035 - .052 in. Solid Wire	
KP1899-4	.045 - .052 in. Cored Wire	

**POWER WAVE®
AC/DC 1000® SD**



CE Filter

This high power filter that enables Power Wave® AC/DC 1000® CE "ready" machine to conform to the EMC standards of Europe and Australia.

Order K2444-3

**MAXsa™ 22 and
MAXsa™ 29 HEADS**



**MAXsa™ 10
Mounting Bracket**

Allows for mounting the MAXsa™ 10 to the TC-3 Travel Carriage. Cannot be used with K299.

Order K2462-1

**TC-3 Self-Propelled
Travel Carriage**

The TC-3 travel carriage allows the mounting of up to two feed heads/ controllers and wire reels to a beam for basic hard automation installations.

Order K325 HCS

(for 5-75 ipm)

Order K325 HCF

(for 15-270 ipm)

(Made to order)



**Large Wire Twinarc®
Contact Assemblies**

Feeds two 5/64 in. (2.0 mm), 3/32 in. (2.4 mm) or 1/8 in. (3.2 mm) wires for submerged arc welding on "Fast-Fill" joints or hardfacing beads.

Order K225



**Twinarc® Solid Wire
Straightener**

Straightens wire diameters .045 thru 3/32 in. (1.2 thru 2.4 mm). Particularly valuable on longer electrical stickout procedures.

Order K281



**Tiny Twinarc® Contact
Assemblies**

Feeds two electrodes for high speed submerged arc welds. Includes contact nozzle, wire guides, drive rolls and guides, and a second wire reel and mounting bracket.

Order K129-xx



**Automatic Flux Hopper
Assembly**

Flux Hopper for MAXsa™ 29 Heads (included standard on the MAXsa™ 22 Heads)

Order K219

**MAXsa™ 22 and
MAXsa™ 29 HEADS
and TC-3 TRACTOR**

Tandem Reels

Two Wire Reel Mounting for TC-3.

Order K390



Tandem Arc Framework

Provides mountings with desired positioning adjustments for two standard Automatic Wire Feed Heads. Includes insulation and hardware to permit direct mounting to a high capacity TC-3 Carriage, or to the user's gantry or fixture for either direction of travel.

Order K387



**Flux Hopper for
Tandem Arc**

Flux Hopper for K387 mountings.

Order K389



Vertical Lift Adjuster

Provides 4 in. (102 mm) hand crank adjustment of vertical head position. It also includes up to 3-3/4 in. (95.2 mm) in-and-out horizontal adjustment with stops that can be preset for simple repetition of the same adjustment.

Order K29



Horizontal Adjuster

Provides crank adjustment of head position. Has 2 in. (51 mm) horizontal travel.

Order K96



**Wire Reel Assembly for
50-60 lb. Coils**

Accommodates 50 lb. (22.7 kg) or 60 lb. (27.2 kg) coils of wire on automatic wire feeders. The unit includes a wire reel mounting spindle and braking system. Cannot be used with K2462-1.

Order K299



SpreadArc Oscillator

Oscillates head across the line of travel. Calibrated dwell time and oscillation speed controls permit the SpreadArc to cover large areas quickly with smooth beads of minimum admixture.

Order K278-1

**MAXsa™ 22 and
MAXsa™ 29 HEADS
and CRUISER™
TRACTOR**

**Wire Straightener (Subarc)
up to 7/32 in. (5.6 mm)**

Includes: A three roll wire straightener with adjustable pressure. (1 included with each tractor and MAXsa™ Feed Head.)

Order K1733-5



**Magnetic Flux Screen
Separator**

For submerged arc welding. Removes foreign magnetic particles from reused flux.

Order K58



**Submerged Arc Contact
Nozzle Assembly for 3/32 in.
(2.4 mm), 1/8 in. (3.2 mm) and
5/32 in. (4.0 mm) electrodes.**

For 5/64 in. (2.0 mm), 3/16 in. (4.8 mm) or 7/32 in. (5.6 mm) sizes, order additional appropriate KP1962 tips. Outer flux cone gives full flux coverage with minimum consumption. (Rated up to 650 amps.)

Order K231-1



K231 nozzle tips

Designed for long life.

Order

KP1962-1B1

for 1/8 in. (3.2mm) wire

KP1962-2B1

for 3/16 in. (4.8 mm) wire

KP1962-3B1

for 3/32 in. (2.4 mm) wire

KP1962-4B1

for 5/32 in. (4.0 mm) wire

KP1962-5B1

for 7/32 in. (5.6 mm) wire

KP2082-2B1

for 5/64 in. (2.0 mm) wire



RECOMMENDED ACCESSORIES AND OPTIONS - CONT.



Positive Contact Assembly
For single arc welding at high currents (optional T12928 water cooling attachment recommended when welding over 600 amps).
Order K148A
(for 3/32 to 1/8 in. wire)
Order K148B
(for 5/32 to 3/16 in. wire)



Concentric Flux Cone Assembly
For use with K148B, Positive Contact Nozzle Assembly. Gives concentric flux coverage around the electrode.
Order K285



Contact Jaw Assembly
Single arc contact jaw assembly for 1/8-7/32 in. (3.2-5.6 mm) diameter wire. Rugged contact jaws for maximum life at currents over 600 amps.
Order K226R



ESO (Extended Stick-Out) Extension
Linc-Fill long stickout extension for K148A Single Arc Positive Contact Nozzle Assembly. Required for long stickout technique.
Order K149-1/8
K149-3/32
K149-5/32



Narrow Gap Deep Groove Nozzle
For single arc 3/32 in. (2.4 mm) diameter wire welding on thick walled steel plate with nearly parallel-sided, narrow gap joint preparations.
Order K386



5 in. Nozzle Extension
Extends the wire for subarc nozzles by 5 inches [up to 1/4 in. (6.4 mm) diameter wire].
Order KP2721-1



CRUISER™ TRACTOR Pendant
Includes: One Tractor pendant with 3.5 ft. (1.1 m) of cable. (1 included with tractor)
Order K2684-1



Tube and Clamp Kit
Includes: Two 15 in. (381 mm) splined tubes, two 30 in. (762 mm) splined tubes, 4 clamps with keys and handles, and mounting hardware.
Order K2716-1

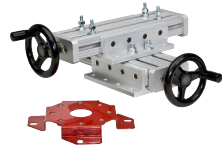

Cross Slide Assembly
Includes: Two slides with 4 in. (102 mm) of travel. (Two slide assemblies and 1 cross slide assembly included with each tractor).
Order K2714-1



Track Section
Includes: a single section of 70 in (1.8 m) of track.
Order K396



50-60 lb. Coil Adapter
Adapts 50-60 lb. (22.7-27.2 kg) coils of Lincoln Electric electrode to 2 in. (51 mm) spindle.
Order K1504-1



FOR OLD K2344-X INSTALLATIONS ONLY

Interface Control Cable (22-pin)
Required to parallel multiple Power Wave® power sources — one per machine required. Can be extended.
Order K1795-XX



System Interface
External controller required for multi-arc applications, provides arc-to-arc phase relationship.
Order K2282-1



Remote Wire Drive Module
Designed for the Power Wave® AC/DC 1000® system, the Remote Wire Drive Module enables you to remove and remotely locate your Wire Drive Module outside of the power source to support extended ArcLink® cable lengths. Recommended for applications where the MAXsa™ feed head is installed at more than 25 ft. (7.6 m) away from the power source.
Order K2626-1



22 pin to 14 pin Adapter Cable Assembly
18 in. (457 mm) long cable adapter from K1785-XX to K2282-1 system interface.
Order K1805-1

WAVEFORM CONTROL TECHNOLOGY®

The waveform may be varied to:

- Control Penetration
- Control Bead Shape
- Minimize arc interactions which can cause arc blow

Waveform Control Technology® capability provides precise control over:

- AC Frequency
- Balance (Percentage of time in the positive polarity portion of one Cycle)
- Offset (Positive/Negative Amplitude)

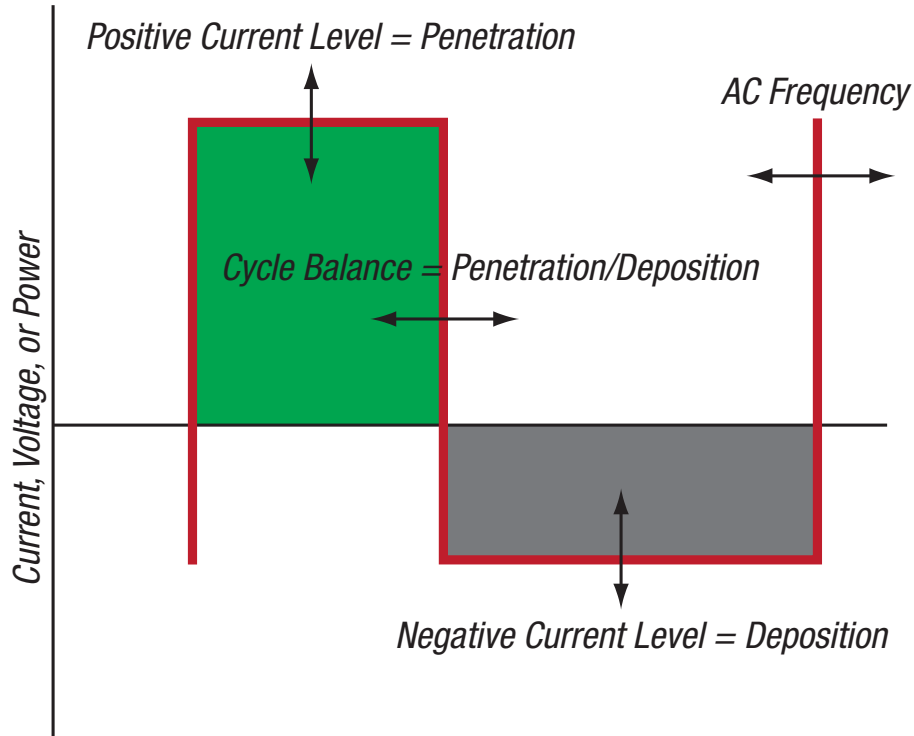

SOFTWARE DRIVEN CONTROL OVER PENETRATION, DEPOSITION RATE AND TRAVEL SPEED

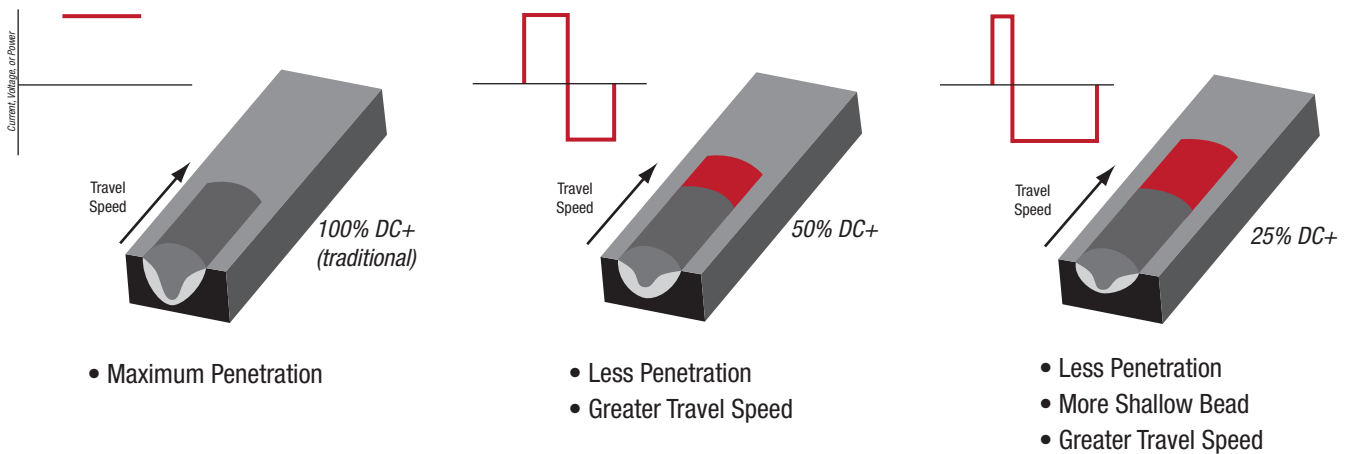

SINGLE ARC AND TWINARC® SUBMERGED ARC WELDING

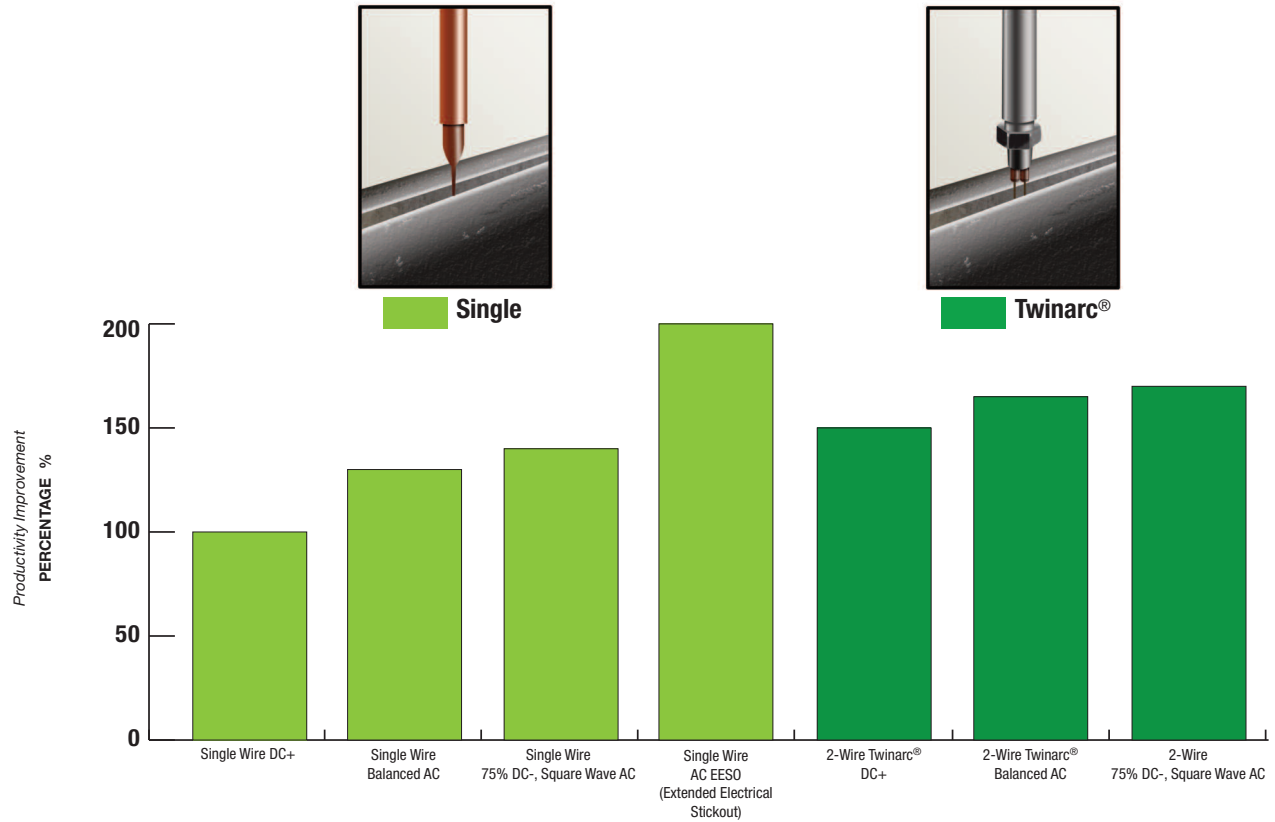

MULTI-ARC SUBMERGED ARC WELDING

Greater Productivity through Enhanced Control
- The Subarc Advantage

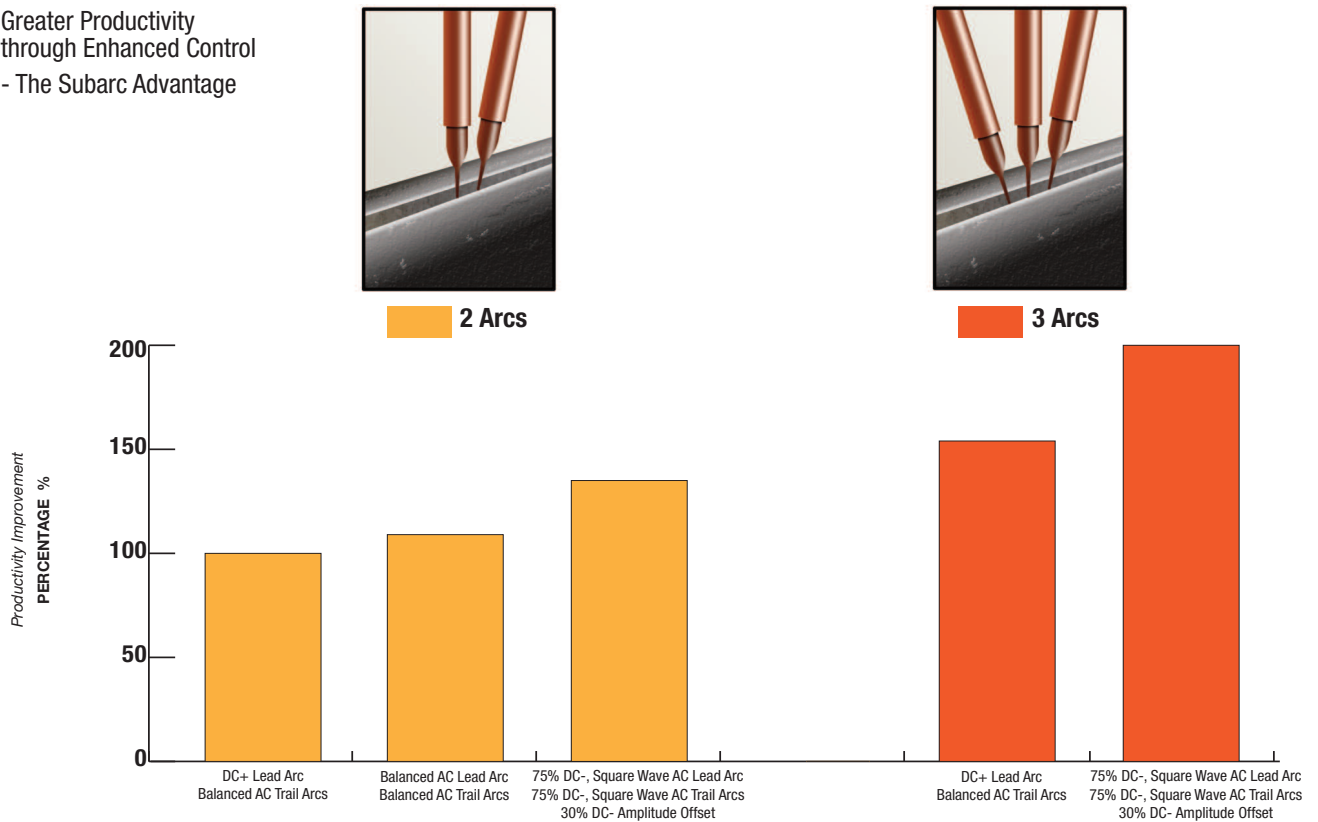

CUSTOMER ASSISTANCE POLICY

The business of The Lincoln Electric Company is manufacturing and selling high quality welding equipment, consumables, and cutting equipment. Our challenge is to meet the needs of our customers and to exceed their expectations. On occasion, purchasers may ask Lincoln Electric for information or advice about their use of our products. Our employees respond to inquiries to the best of their ability based on information provided to them by the customers and the knowledge they may have concerning the application. Our employees, however, are not in a position to verify the information provided or to evaluate the engineering requirements for the particular weldment. Accordingly, Lincoln Electric does not warrant or guarantee or assume any liability with respect to such information or advice. Moreover, the provision of such information or advice does not create, expand, or alter any warranty on our products. Any express or implied warranty that might arise from the information or advice, including any implied warranty of merchantability or any warranty of fitness for any customers' particular purpose is specifically disclaimed.

Lincoln Electric is a responsive manufacturer, but the selection and use of specific products sold by Lincoln Electric is solely within the control of, and remains the sole responsibility of the customer. Many variables beyond the control of Lincoln Electric affect the results obtained in applying these types of fabrication methods and service requirements.

Subject to Change – This information is accurate to the best of our knowledge at the time of printing. Please refer to www.lincolnelectric.com for any updated information.

Visit www.lincolnelectric.com/subarc



THE LINCOLN ELECTRIC COMPANY

22801 St. Clair Avenue • Cleveland, OH U.S.A. • 44117-1199

Phone: +1.216.481.8100 • www.lincolnelectric.com