

## Disk Centrifuge General Description:

In modern separation industry disk centrifuge developed as the main separation machinery for every producer.

Disk Centrifuge: With the high G-force and automatically running system, disk centrifuge can be applied to clarify and separate various liquid which can adjust the discharge rate to keep the clarify or separation result as well.

## Centrifuge machine Standard design

The machine consists of a frame that has a horizontal drive shaft with clutch and brake, worm gear, lubricating oil bath and vertical bowl spindle in the lower part.

The bowl is mounted on top of the spindle in the lower part. The bowl is mounted on top of the spindle, inside the space formed by the upper parts of the frame, the ring solid cover, the collecting cover, and frame hood. The feed and liquid discharge system, including the paring disc pump for the heavy phase, also rests on this structure. All parts in contact with the process liquid are made of stainless steel. The bowl is of the solid-ejecting disc type with hydraulic operating system. The electric motor is of the variable frequency drive type or of controlled-torque type.

## Basic equipment

Concentrator or purifier parts, inlet and outlet devices, revolution counter, set of erosion-protective parts, illuminated sight glass box for light phase outlet, vibration switch, vibration-isolating base plate, flange motor, set of tool and standard set of spare.

## Optional extras

Started equipment, frequency converter, discharge control panel, standard set of fittings, set of CIP valves and fittings and serviceability package for online viewing of separator status



## Material data

Bowl body, hood and locking ring S.S304

Solids cover and frame hood S.S304

Frame bottom parts green cast iron

In and outlet parts S.S304

Gasket and o-ring Nitrile rubber



## Operating principles

Separation takes place inside a rotating bowl. The feed is introduced to the rotating centrifuge bowl from the top via a stationary inlet pipe (1), and is accelerated in the distributor (2), which was specially designed to ensure smooth acceleration of the feed liquid (4). Leaving the distributor, the feed enters the disc stack (3). The separation into liquid-liquid-solid takes place between the discs, with the oil phase moving through the disc stack to the center. When it reaches the center, it is discharged through hole (5) and ejected into the collecting frame. The water and heavy solid separated from the oil move to the periphery, and the water flows via channels in the top disc (6) to the paring chamber, where it is pumped out of the rotor by means of a built-in paring disc (7). During purification, hot water is fed into the inlet of the bowl before the process liquid is introduced. The water forms a seal around the outer edge of the top disc. The solid collect in the periphery where they are discharged intermittently via the centrifuge cyclone. The solid are discharged by means of a hydraulic system, which forces the sliding bowl bottom (8) to drop down at preset suitable intervals, thus opening the solid ports at the bowl periphery

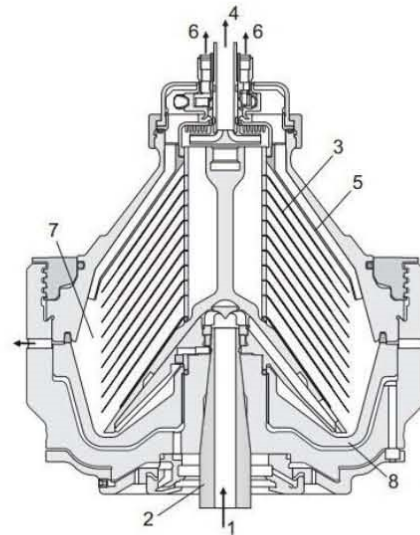

**Centrifuge machine Main Parameter**

Model	Bowl Speed(rpm)	Capacity(Per Hour)	Running Load(KWatts)	Dimensions, Overall (mm)		
				Width	Front-to-Back	Height
250	7300	1000	4	850	850	1200
400	7038	3000	7.5	1500	1100	1550
500	6600	5000	15.5	1772	1500	1855
550	6200	8000	18.5	1970	1560	1970
700	4500	35000	55	2097	1897	2384

Disc Stack Centrifuge Out-shape

